

Items Supplied >

- 1 - Sissy Bar w/pad
- 2 - Brackets
- 4 - 8mm x 20mm Button head Bolts
- 4 - 8mm x 30mm Button head Bolts
- 4 - Washers

Application(s) >

- | | |
|------------------------|-----------|
| YAMAHA: ROAD STAR 1600 | 1999-2003 |
| YAMAHA: ROAD STAR 1700 | 2004-2014 |

Instruction Manual >

02-7750 / 02-8750

Page 1 of 1

READ ALL INSTRUCTIONS CAREFULLY AND COMPLETELY BEFORE INSTALLING YOUR NEW SISSY BAR!

1. Remove the two (2) rear bolts on the right fender rail and remove the stock fender rail. CAUTION: remove only one side of the mounting bolts at a time to prevent the fender from rotating or falling.
2. Install the supplied brackets with the bent portion toward the outside (part number inside). Place two (2) supplied washers on each side between the fender and the brackets. Then, position the stock fender rail over these and using the supplied 8mm x 30mm bolts put in place but do not tighten. Repeat this procedure for the left side.
3. Install the sissy bar to the brackets using the supplied 8mm x 20mm bolts then tighten all bolts to factory specs.

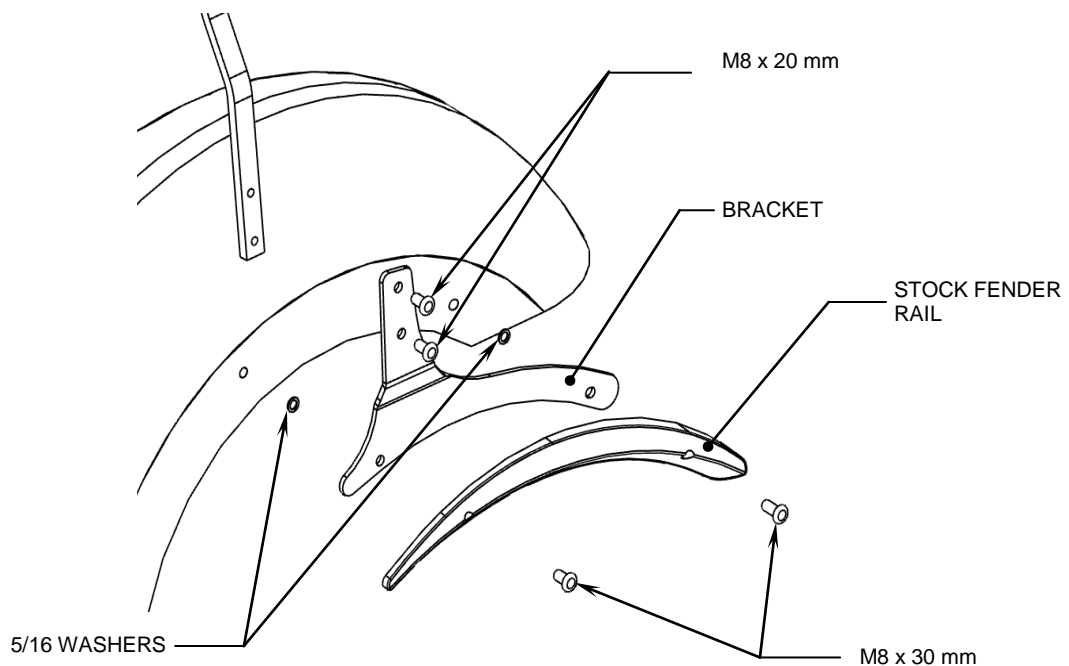

* Cobra® recommends you always wear a helmet while riding. Please never operate your motorcycle while under the influence of alcohol and/or drugs. Enjoy the new look of your motorcycle and please ride safely.