

## Items Supplied >

- 1 – INTAKE COVER
- 1 – VENTURI AIR FILTER
- 1 – INTAKE SCREEN ASSEMBLY
- 1 – BILLET VELOCITY STACK
- 1 – MOUNTING PLATE
- 1 – SUPPORT BRACKET
- 3 – BOLT, M5 X 16mm, ALLEN
- 3 – BOLT, 1/4"-20 X 5/8", HEX FLANGE
- 4 – BOLT, 1/4"-20 X 1/2", BUTTONHEAD
- 4 – WASHER, INTERNAL TOOTHED
- 1 – O-RING, 1.25" I.D. X .125", SILICONE (SMALL)
- 1 – O-RING, 3.25" I.D. X .125", SILICONE (LARGE)

## Application(s) >

YAMAHA STRYKER 2011-2018

## Instruction Manual >

06-0270-SB

Page 1 of 2

### Read all instructions carefully and completely before installing your new POWRFLO™ Intake.

1. Remove the (4) bolts that hold on the stock air cleaner cover. Remove chrome cover and filter from air box.
2. Remove the air box by loosening the (3) allen bolts around the air inlet and the (1) M6 hex nut from the lower portion of the air box. See Figure 1. Disconnect the hose from the backside of the air box. Remove the bracket which holds the bolt that secured the M6 hex nut; reinstall bolts after the bracket has been removed.
3. Insert the supplied O-rings into the grooves of the supplied velocity stack. NOTE: Do not attempt to stretch o-rings into grooves; position o-rings evenly around groove and use gentle force (No tools).
4. Bolt the velocity stack to the throttle body using the (3) supplied M5 x 16mm allen bolts and tighten.
5. Position the mounting plate over the velocity stack (with the welded tube toward the inside) and secure using (3) supplied 1/4"-20 x 1/2" buttonhead bolts and lock washers, finger tighten only. See Figure 3.

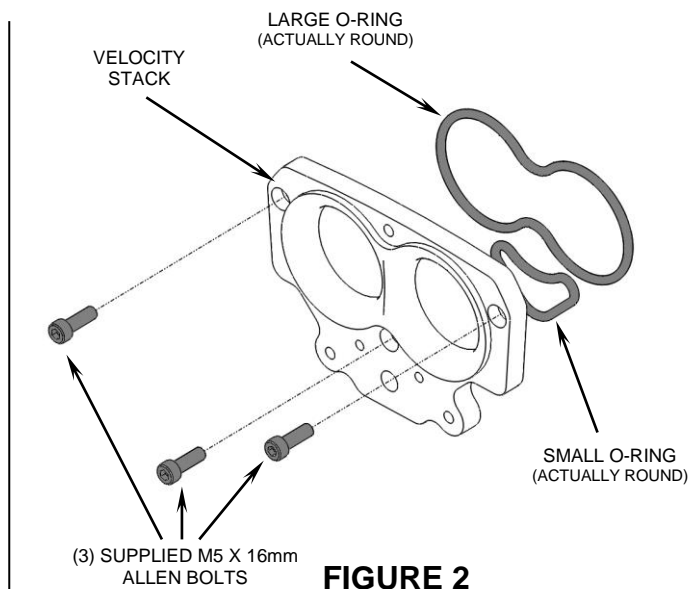
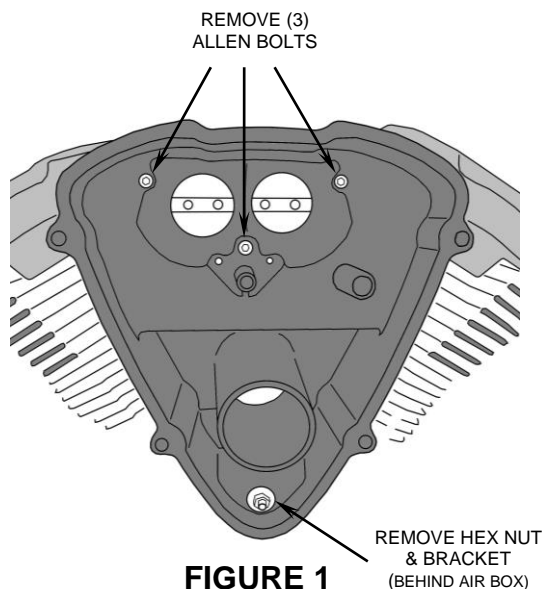

**California Customers:** In California, aftermarket parts that have been identified specifically as replacement parts or that have received an Air Resources Board Executive Order may be used on street motorcycles. All other emissions related aftermarket parts are for competition use only. A list of replacement parts and EO parts, and corresponding fitment is provided at: [www.cobrausa.com](http://www.cobrausa.com)

DISCLAIMER: NOT LEGAL FOR SALE OR USE IN CALIFORNIA ON ANY POLLUTION CONTROLLED MOTOR VEHICLE. THE SALE, USE, OR INSTALLATION OF THIS PRODUCT MAY ALSO BE ILLEGAL NATIONWIDE UNDER THE FEDERAL CLEAN AIR ACT (42 U.S.C. § 7522(A)(3)).

6. Remove the two allen bolts at the base of the cylinders and install the supplied support bracket. Secure the support bracket to the mounting plate using the (1) remaining 1/4" buttonhead bolt. See Figure 3 & 4.
7. Fully tighten the (4) 1/4"-20 buttonhead bolts (Steps 5 & 6) and the stock allen bolts (Step 6).
8. Attach the hose and hose clamp that was disconnected in Step 2 to the tube on the mounting plate.
9. Insert the intake screen into place so the holes in the bent tabs align with the threaded bosses in the intake cover, see Figure 5 for orientation. Place the supplied venturi filter into the intake cover.
10. Place intake cover over the mounting plate and align the mounting holes to the threaded bosses. Insert the (3) supplied 1/4" hex flange bolts and tighten the mounting plate to the intake cover. See Figure 5.

