

Items Supplied >

- 1 – SLIP-ON MUFFLER ASSEMBLY
- 1 – HEATSHIELD, INTERMEDIATE
- 1 - BRACKET, EXHAUST MOUNT
- 1 – CLAMP, #27-61MSC
- 2 – BOLT, M10 X 30mm HEX FLANGE W/ LOCTITE
- 2 – BOLT, 5/16 X 5/8 HEX FLANGE W/ LOCTITE
- 2 – SCREW, M6 X 10mm BUTTONHEAD

Application >

YAMAHA STRYKER 2011 -2018

Instruction Manual >

2270B

Page 1 of 3

Read all instructions carefully and completely before installing your new exhaust system!

1. Remove the stock slip-on muffler and mount in one assembly by removing (3) M10 bolts. Stock mount, clamp and bolts will not be reused.
2. Loosen the front and rear headpipe acorn nuts along with the stock slip collar clamp between front and rear headpipes, but **DO NOT REMOVE**, see Figure 1. This will allow for proper fitment of Cobra supplied muffler and heatshield.

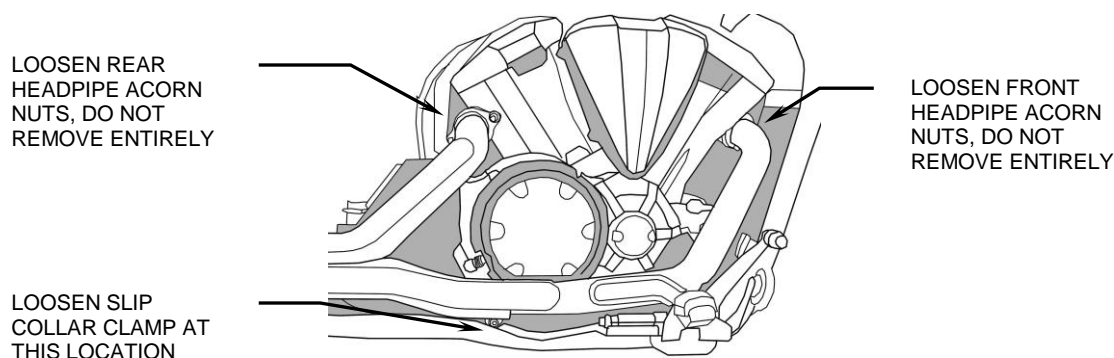

FIGURE 1

3. Install Cobra supplied exhaust mount bracket on to Cobra slip-on muffler using supplied 5/16 X 5/8 hex flange bolts. Be sure orientation is as shown in Figure 2. **DO NOT TIGHTEN AT THIS TIME.**
4. Place supplied 27-61 clamp over muffler inlet and begin to push the muffler and exhaust bracket onto headpipe collector until muffler bracket holes align with the holes in the left side frame member. See Figure 2, for clamp orientation.
5. Insert the supplied M10 X 30mm hex flange bolts through the Cobra Supplied exhaust bracket and into the tapped bosses on frame. **DO NOT FULLY TIGHTEN.**

* *Cobra® recommends you always wear a helmet while riding. Please never operate your motorcycle while under the influence of alcohol and/or drugs. Enjoy the new look of your motorcycle and please ride safely.*

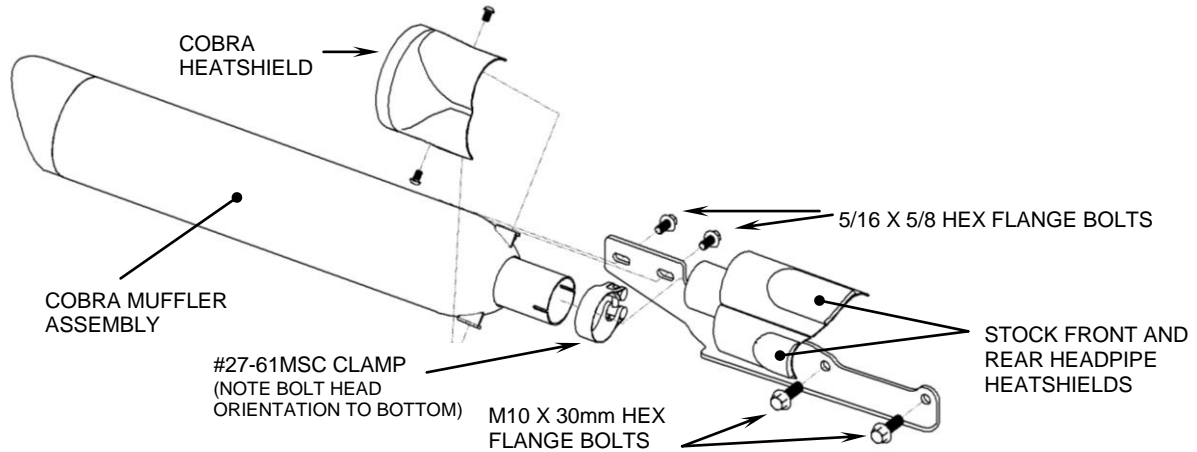

FIGURE 2

6. Position the Cobra intermediate heatshield over the front of the muffler and rear portion of the headpipe heatshields. Align holes in heatshield with mounting brackets on muffler body, install supplied M6 X 10 mm Buttonhead screws in each position, but **DO NOT TIGHTEN**. **NOTE:** It may be necessary to rotate front headpipe and rear headpipe slightly at the stock slip collar clamp loosened in Step 2 for heatshield to align correctly to stock headpipe heatshields.
7. Check muffler is level with front and rear headpipe heatshields and snug 5/16 X 5/8 hex flange bolts and M10-1.25 x 30mm flange bolts securing muffler and bracket to motorcycle, see Figure 2.
8. Check alignment of Cobra intermediate heatshield and be sure it is still properly aligned, snug the M6 X 10mm Buttonhead screws securing the heatshield. Note: It may be necessary to press the heatshield on the top and bottom in the direction of the arrows as shown in Figure 3, and once fully seated firmly tighten the M6 buttonhead screws.

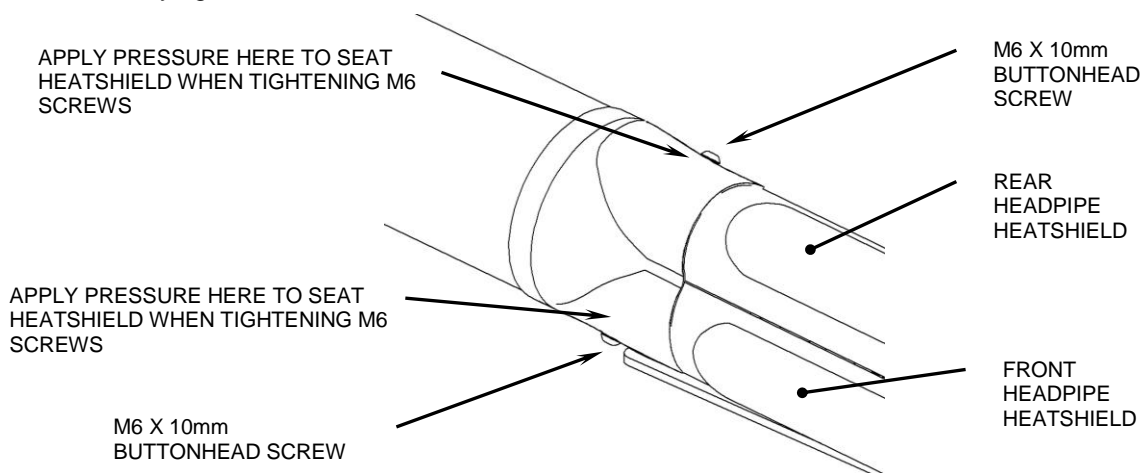

FIGURE 3

9. Follow this sequence for fully tightening all of the exhaust components: First tighten the acorn nuts securing each headpipe, both front and rear. Next, fully tighten the 5/16 X 5/8 and M10-1.25 x 30mm hex flange bolts securing muffler and bracket to motorcycle. Continue by tightening the stock slip collar clamp between front and rear headpipes. Finally tighten the MSC 27-61 clamp securing the Cobra muffler to headpipe collector. See Figure 4, for tightening sequence.

NOTE: (If the muffler clamp is slid past the slots in the muffler to far, the clamp will not tighten properly.)

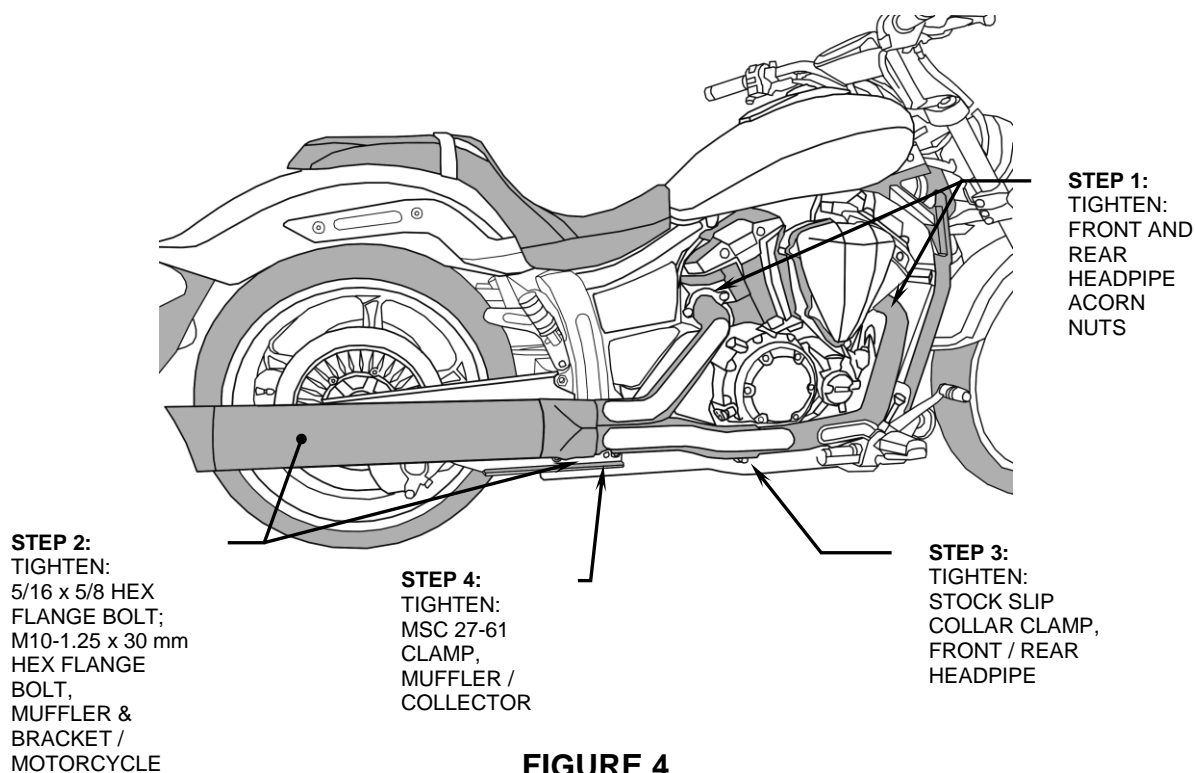

FIGURE 4

IMPORTANT: Cobra highly recommends using a Fi2000® Fuel Management System to help eliminate lean conditions and popping sounds. (Cobra Part #: 92-1770AT Powrpro Tuner, 92-1770CL for 49 state models and Part# 92-1770CL-50 for CA models.

NOTE: To clean your black exhaust system use a liquid based soap detergent, such as dishwashing soap applied with a soft cloth and rinse with clean water. Note: Avoid abrasive cleaning methods such as granular or dry cleansers, simple green, scotch-brite or steel wool pads. Abrasives may breach the coating and shorten life.

California does not allow the use of aftermarket exhaust systems that remove original equipment catalysts, (except for racing use only) unless the Air Resources Board has issued an Executive Order for that system.