

## Items Supplied >

2 – FRONT & REAR EXHAUST HEADPIPE  
2 – FRONT & REAR EXHAUST HEATSHIELD  
1 – COLLECTOR HEATSHIELD  
1 – MUFFLER  
1 – EXHAUST BRACKET  
2 – FLANGE, STEEL  
5 – CLAMPS, HEATSHIELDS  
2 – CLAMPS, HEADPIPES  
1 – CLAMP, MUFFLER  
2 – BOLT, HEX 5/16-18 x .63  
2 – NUT, NYLOCK M10  
2 – BOLT, M10 x 30mm

## Application(s) >

YAMAHA ROADSTAR 1600/1700 99-07

## Instruction Manual >

2421/2471

Page 1 of 2

**PRIOR TO INSTALLATION, MAKE SURE YOUR STOCK HEADPIPE GASKETS ARE IN GOOD SHAPE. IF YOU HAVE ANY DOUBTS AS TO THEIR CONDITION, REPLACE THEM.**

**Read all instructions carefully and completely before installing your new exhaust system**

1. Loosen and move the right side floorboard out of the way to ease installation of the exhaust.
2. Remove stock exhaust system.
3. Remove the stock exhaust-mounting bracket. NOTE: The bracket brake line guide must be cut and spread apart so you can remove the brake line from the bracket. Refer to Figure 1.
4. Install the new exhaust-mounting bracket using the supplied M10 hex bolts and nylock hex nuts but **DO NOT TIGHTEN** at this time. Connect the brake hose clip to the bracket using the stock M6 bolt. Refer to Figure 2.
5. Install the front and rear head pipes onto motorcycle using the supplied flanges, stock bolts and stock nuts. Make sure pipes are parallel to each other.
6. Remove the muffler assembly from the box and slide one supplied clamp #27-61MSC onto each muffler tube. Refer to Figure 3 for proper alignment.
7. Slide the muffler assembly onto the head pipes by tapping on the head pipes with your hand as you push the mufflers forward making sure the assembly slides as far forward as possible. Secure the muffler assembly to the mounting bracket using the supplied 5/16-18 bolts but **DO NOT TIGHTEN** at this time.
8. Make sure the muffler assembly is properly aligned then tighten the following in order, muffler bracket to the frame, muffler assembly to the muffler bracket, head pipe flanges to the motor (slowly tighten opposing nut) and muffler clamps. (NOTE: If the muffler clamps are slid to far up the muffler or past the three slots, the clamps will not tighten.)
9. Unscrew the remaining hose clamps and feed the tail end of the clamp through the clips on the inside of the heat shields. The screw end of the hose clamp should be accessible for tightening but not visible when the heat shields are mounted to the pipes.
10. Place the heatshields on the headpipes and align at collector. **DO NOT TIGHTEN** at this time. Feed the tail end of the #28 hose clamp thru the collector heat shield and snap into place over the megaphone and heat shields (See figure 4). Tighten all clamps.
11. Reinstall the right side floorboard and tighten bolts to factory specifications.
12. Make sure all the hardware (brackets, headpipes, heatshields, and mufflers) has been tightened appropriately before starting your motorcycle.

*\* Cobra recommends you always wear a helmet while riding. Please never operate your motorcycle while under the influence of alcohol and/or drugs. Enjoy the new look of your motorcycle and please ride safely.*

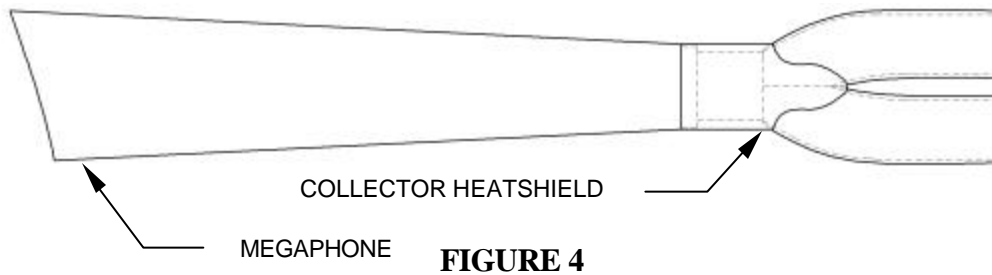
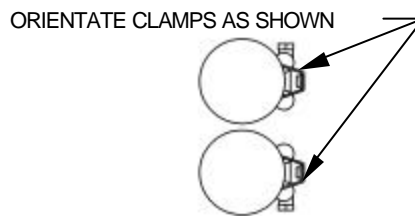
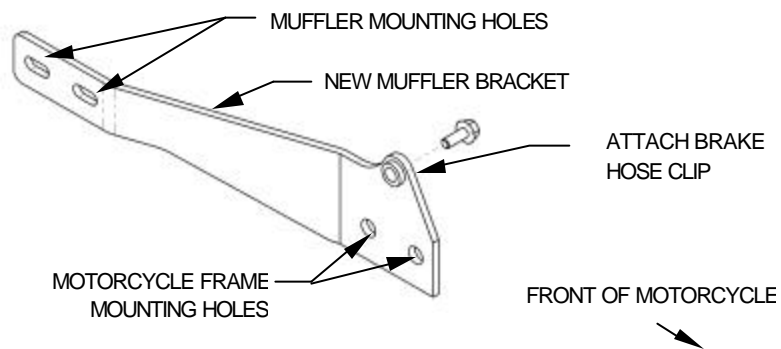
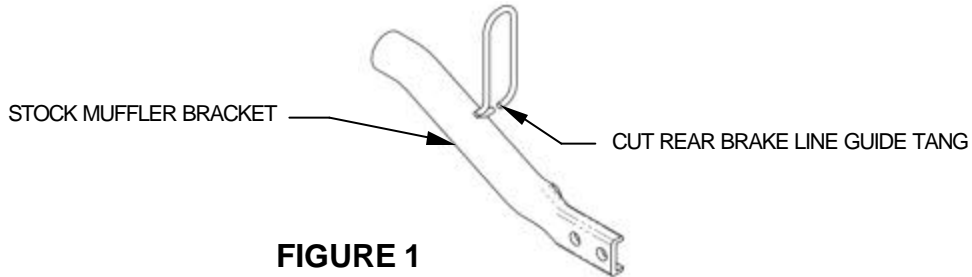

**IMPORTANT:** It is recommended that you re-jet your bike with a Cobra Jet Kit, available from Cobra. RoadStar 1600 part #92-2271, RoadStar 1700 part #92-2272.

Before starting your engine remove all fingerprints from chrome with a quality wax or chrome polish. Failure to do so can cause discoloration. Due to fluctuations in carburetor settings, timing, etc., Cobra Engineering does not warrant against chrome discoloration.