

## Items Supplied >

- 1 – FRONT EXHAUST W/HEATSHIELD ASSEMBLY
- 1 – REAR EXHAUST W/HEATSHIELD ASSEMBLY
- 1 – EXHAUST BRACKET
- 6 – HOSE CLAMPS
- 4 – BOLT, HEX 5/16-18 x .63
- 2 – SCREW, BUTTON ¼-20 x .38
- 2 – BILLET MUFFLER TIPS

## Application(s) >

- |                      |       |
|----------------------|-------|
| Suzuki Intruder 1500 | 98-04 |
| Suzuki C90           | 05-09 |

## Instruction Manual >

3616 / 3620

Page 1 of 2

**PRIOR TO INSTALLATION, MAKE SURE YOUR STOCK HEADPIPE GASKETS ARE IN GOOD SHAPE. IF YOU HAVE ANY DOUBTS AS TO THEIR CONDITION, REPLACE THEM.**

**Read all instructions carefully and completely before installing your new exhaust system**

1. Remove the stock exhaust system.
2. Remove the exhaust-mounting bracket from the box and attach it to the outside of the stock exhaust mount on the frame using the stock bolt, washers and nut. **DO NOT TIGHTEN** at this time. See Figure 1.
3. Loosen the right side rider floorboard mount to ease installation but **DO NOT REMOVE**.
4. Install the front and rear muffler assemblies on to the motorcycle and mounting bracket using the supplied 5/16 flange bolts and stock flange nuts. **DO NOT TIGHTEN** at this time.
5. Make sure the muffler assemblies are parallel to each other then tighten in the following order: muffler bracket to the frame, muffler assembly to the muffler bracket, head pipe flanges to the motor (slowly tighten opposing nut.)
6. Unscrew the remaining hose clamps and feed the tail end of the clamp through the clips on the inside of the heat shields. The screw end of the hose clamp should be accessible for tightening but not visible when the heat shields are mounted to the pipes.
7. To install the front heatshield, first slide the rear portion of the heatshield over the muffler, continue to slowly slide it forward pushing the front of the shield gently into place between the frame and motor (Hint: Spread the hose clamps apart slightly to make it easier to slide them over the muffler assembly and head pipes). Snug the heatshield clamps but **DO NOT TIGHTEN**.
8. Install the rear heatshield the same way as the front heatshield.
9. Make sure the front and rear heatshields are even on the back with each other. Install one billet tip on each heatshield. Fasten the tips with the supplied ¼-20 screws making sure they snug up against the heatshield leaving no gap between the tip and heatshield when tightened. **If it is difficult to slide the tips into the heatshields loosen the clamps on the heatshield, failure to do this may cause damage to the chrome tips.**
10. Tighten the clamps on the heatshields.
11. Retighten the floorboard mount loosened in step 3 to factory specifications.

**Continued on next page!!**

**\* Cobra® recommends you always wear a helmet while riding. Please never operate your motorcycle while under the influence of alcohol and/or drugs. Enjoy the new look of your motorcycle and please ride safely.**

12. Make sure all the hardware (brackets, headpipes, and heatshields) have been tightened appropriately and cleaned before starting your motorcycle.

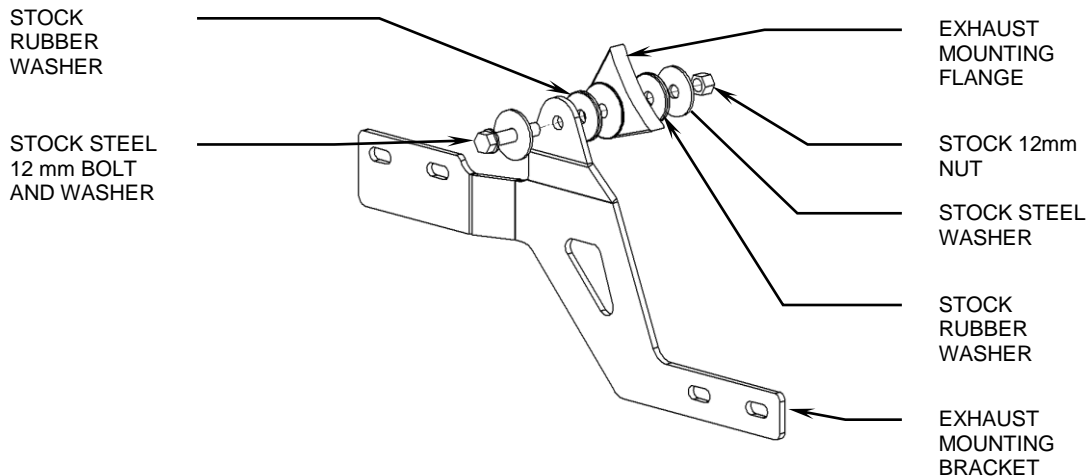

FIGURE 1

**IMPORTANT: Intruder 1500 Owners:** It is recommended that you re-jet your bike with a Cobra Jet Kit, available from Cobra part #92-3166.

**C90 Owners:** It is recommended that you install a Cobra Fi2000® Digital Fuel Processor with your Cobra exhaust system. Cobra is not responsible for the performance of any other fuel management system used with Cobra exhaust systems.

**Please reference these part numbers for C90 Fi2000 (Part#s 92-1840)**

**Before starting your engine remove all fingerprints from chrome with a quality wax or chrome polish. Failure to do so can cause discoloration. Due to fluctuations in carburetor settings, timing, etc., Cobra Engineering does not warrant against chrome discoloration.**

California does not allow the use of aftermarket exhaust systems that remove original equipment catalyts, (except for racing use only) unless the Air Resources Board has issued an Executive Order for that system.