

Items Supplied >

- 1 – FRONT MUFFLER ASSEMBLY
- 1 – REAR MUFFLER ASSEMBLY

Application >

HARLEY:
FATBOY/DEUCE

00-06

Instruction Manual >

6000B

Page 1 of 1

Read all instructions carefully and completely before installing your new slip-on mufflers

1. Remove the stock muffler mounting bolts and save. Loosen the stock muffler clamps then pull both mufflers (in unison) from the headpipes. Save the stock clamps because they will be reused.
2. Remove gasket from muffler crossover slip and install into the supplied rear slip-on muffler. If needed, a replacement gasket can be purchased through your dealer (HD Part #65830-03).
3. Slide the supplied stock clamps over the slip-on mufflers and position them as shown in Figure 1.
4. **NOTE: THE MUFFLER WITH THE COBRA LOGO WILL ALWAYS BE THE REAR CYLINDER.** Connect the crossover slips together and slide both mufflers onto the headpipes in unison (reverse the order of removal) until the mounting holes align.
5. Fasten the mufflers using the stock mounting bolts in the same manner as stock but **do not tighten**. Verify that the gap, where the mufflers meet the stock heatshields, is similar to the gap the stock mufflers allotted.
6. Check all clearances and alignments, then tighten the clamps. (**NOTE:** The muffler clamps should be flush with the end of the muffler when tightened. See **Figure 2**. If the muffler clamps are slid forward past the slots on the slip collar the clamps will not tighten the mufflers properly. Also, make sure the clamp spacer is not over the slots. The slots need to be covered by the clamp band so that it seals the muffler properly. Rotate the clamp if necessary). Tighten all loose bolts to factory specifications. Tighten all loose bolts to factory specifications.
7. **NOTE:** The exhaust tips may be loosened and oriented to various positions for different visual effects.
8. **IMPORTANT: Before starting your engine remove all fingerprints from all exhaust surfaces. To clean your black exhaust system use a liquid based soap detergent, such as dishwashing soap applied with a soft cloth and rinse with clean water. Note: Avoid abrasive cleaning methods such as granular or dry cleansers, simple green, scotch-brite or steel wool pads. Abrasives may breach the coating and shorten life.**

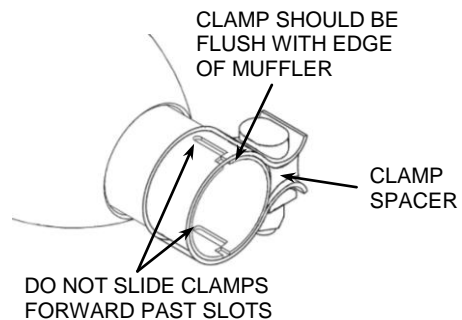
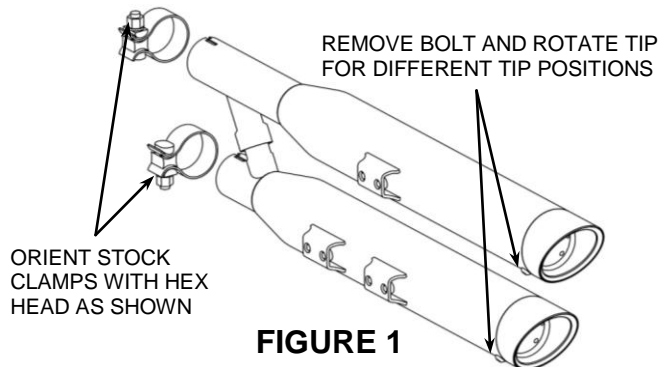

POSITION OF MUFFLERS AND MOUNTING BRACKETS SHOWN ABOVE MAY VARY FROM ACTUAL APPLICATION

REPLACEMENT E-GLASS PACKING AND OPTIONAL 1 $\frac{3}{4}$ " QUIET CORES MAY BE PURCHASED THROUGH YOUR DEALER OR ONLINE AT WWW.COBRAUSA.COM

IMPORTANT: To achieve optimum performance from your new mufflers it is suggested that you install a Cobra Fi2000® Digital Fuel Processor.

DISCLAIMER: NOT LEGAL FOR SALE OR USE IN CALIFORNIA ON ANY POLLUTION CONTROLLED MOTOR VEHICLES.