

Items Supplied >

- 1 – INTAKE COVER W/ INTAKE SCREEN ASSEMBLY
- 1 – VENTURI AIR FILTER
- 1 – BILLET VELOCITY STACK
- 1 – MOUNTING PLATE
- 1 – INTAKE GASKET
- 2 – BREATHER BOLT, 3/8"-16 X 1" W/ TEFLON SEALANT
- 3 – BOLT, 1/4"-20 X 3/4", BUTTONHEAD W/ LOCK PATCH
- 3 – BOLT, 1/4"-20 X 5/8", HEX FLANGE
- 3 – LOCK WASHER, 1/4" TOOTHED
- 2 - BREATHER HOSES

Application(s) >

- | | |
|---------------------------|-------|
| HARLEY: | |
| DRESSER | 08-16 |
| SOFTAIL(THROTTLE BY WIRE) | 16-17 |

NOTE: DOES NOT FIT CVO OR S MODELS

Instruction Manual >

606-0100-SB

Page 1 of 2

Read all instructions carefully and completely before installing your new POWRFLO™ Intake.

1. Remove the allen bolt from the center of the stock air cleaner to remove the cover. Remove the (3) bolts securing the formed bracket located on top of the air filter. Then remove and discard the air filter, air box and seals/gaskets.
2. Remove and discard the (2) stock breather bolts, (2) stock o-rings, and (2) stock breather hoses from the cylinder heads.
3. Insert the (3) supplied 1/4"-20 x 3/4" buttonhead bolts and lock washers through the mounting holes in the velocity stack and mounting plate. While holding that assembly together with one hand, insert the (2) breather hoses through the mounting plate and into the velocity stack with the hoses rotated outward, as shown in Figure 1. **NOTE:** Make sure the longer legs of hoses are bottomed out in the back of the velocity stack.
4. Join together the assembly from Step 3 with the supplied gasket then start threading the (3) buttonhead bolts into the throttle body, but do not tighten.

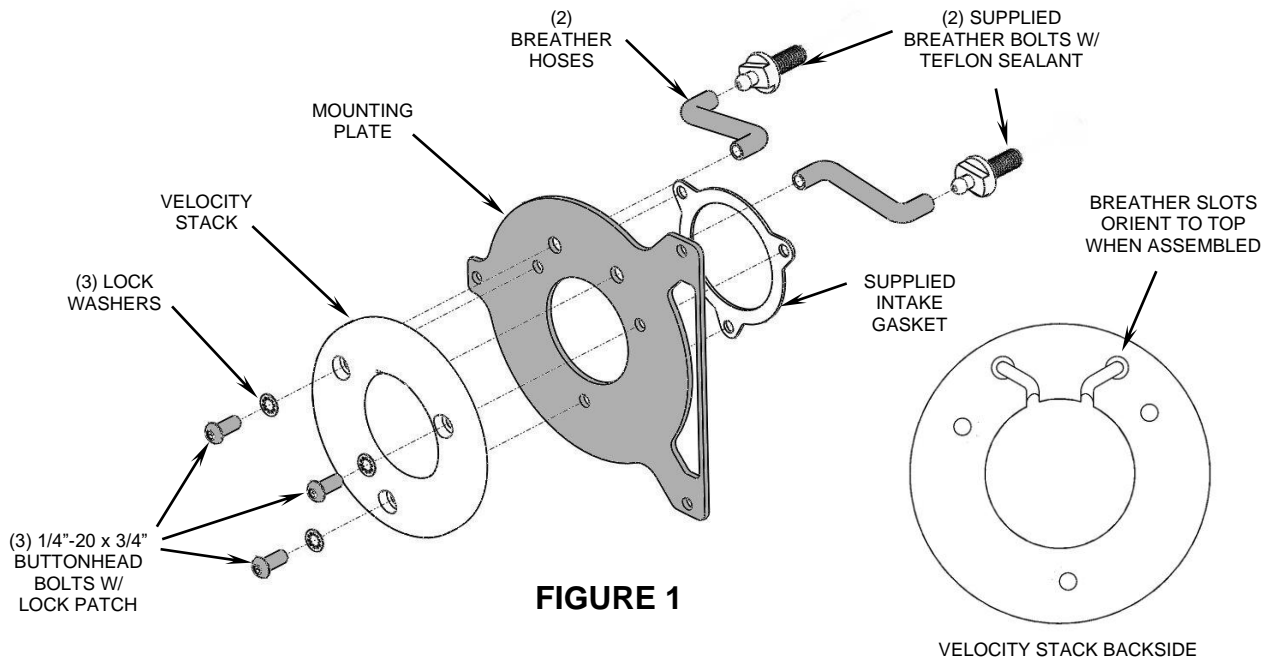

DISCLAIMER: NOT LEGAL FOR SALE OR USE IN CALIFORNIA ON ANY POLLUTION CONTROLLED MOTOR VEHICLE. THE SALE, USE, OR INSTALLATION OF THIS PRODUCT MAY ALSO BE ILLEGAL NATIONWIDE UNDER THE FEDERAL CLEAN AIR ACT (42 U.S.C. § 7522(A)(3)).

5. Insert the breather bolts into the cylinder heads and full tighten. Now snug the (3) buttonhead bolts evenly, and then fully tighten them to the throttle body.
6. Insert outer end of rubber hoses over nipples on breather bolts.
7. Place the supplied venturi filter onto the velocity stack. Insert the intake screen assembly into the POWRFLO™ intake cover so the holes in the bent tabs align with the threaded bosses.
8. Place the intake cover over the air filter and align threaded bosses with the mounting plate holes. Insert the (3) supplied 1/4"-20 x 5/8" hex flange bolts through the mounting plate, intake screen and into the intake cover then tighten. See Figure 2.

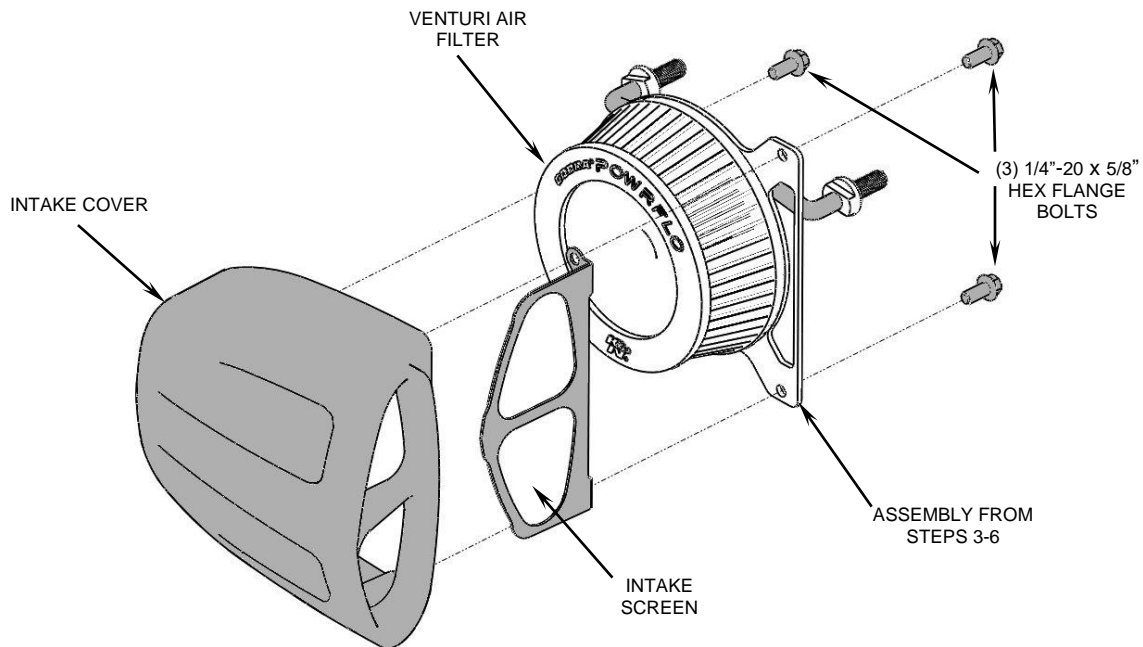

FIGURE 2

California Customers: In California, aftermarket parts that have been identified specifically as replacement parts or that have received an Air Resources Board Executive Order may be used on street motorcycles. All other emissions related aftermarket parts are for competition use only. A list of replacement parts and EO parts, and corresponding fitment is provided at: www.cobrausa-hd.com