

Items Supplied >

- 1 – RIGHT SIDE CASE GUARD
- 1 – LEFT SIDE CASE GUARD
- 2 – M10 X 50 mm HEX FLANGE BOLT
- 2 – M10 X 100 mm HEX FLANGE BOLT
- 4 – BLACK POWDER COATED SPACERS

Application(s) >

SUZUKI M109 06-14

Instruction Manual >

01-3345

Page 1 of 1

Read all instructions carefully before installing your new Cobra® product!

ATTENTION: ONLY INSTALL ONE CASE GUARD PER SIDE AT A TIME, TO PREVENT THE ENGINE FROM SHIFTING IN THE FRAME, CAUSING DIFFICULTY DURING REASSEMBLY!

1. Remove the bolts securing the right side rider footpeg assembly; these will not be used again.
2. Remove the right side case guard from the box and insert two M10 x 50 mm bolts through the mounting holes from the outside, then through two of the supplied black spacers, see Figure 1.
3. Now position the right side case guard up against the footpeg mount and insert the bolts and tighten to factory specifications. Be careful not to cross-thread the bolts when starting them into the holes.
4. Once the right side case guard has been installed and the bolts tightened, remove the stock bolts securing the left side footpeg mounts.
5. Insert two M10 x 100 mm bolts through the mounting holes from the outside on the left side case guard, then through two of the supplied back spacers, this will install symmetrical to Figure 1.
6. Now position the left side case guard up against the footpeg mount and insert the bolts through the footpeg mount, frame and engine case mounting bracket tighten to factory specifications. Be careful that the bolts start properly into the tapped holes, this side may be a bit more difficult then the right side because the bolts must thread into the engine case mounting bracket as well.

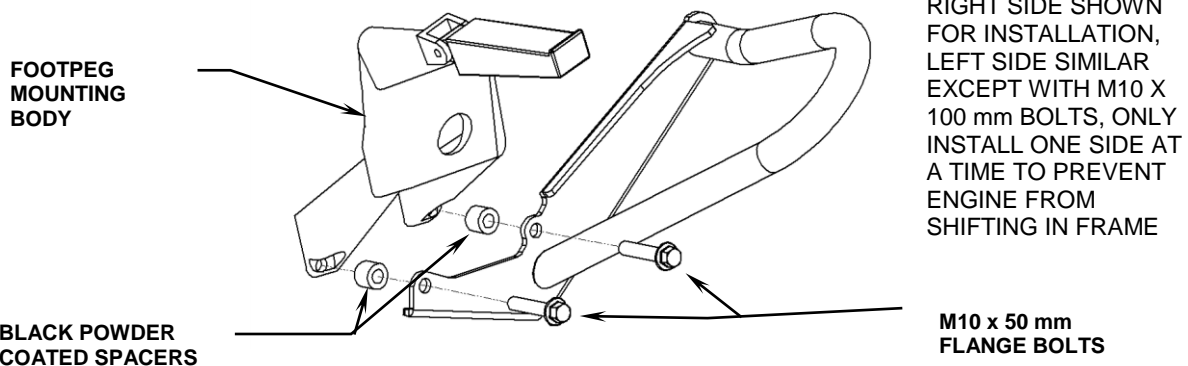

*** Cobra® recommends you always wear a helmet while riding. Please never operate your motorcycle while under the influence of alcohol and/or drugs. Enjoy the new look of your motorcycle and please ride safely.**