

Items Supplied >

- 1 – INTAKE COVER
- 1 – VENTURI AIR FILTER
- 1 – INTAKE SCREEN ASSEMBLY
- 1 – BILLET VELOCITY STACK
- 1 – MOUNTING PLATE
- 1 – FUEL INJECTOR COVER
- 1 – THROTTLE SPACER
- 1 – SUPPORT BRACKET
- 4 – BOLT, 1/4"-20 X 5/8", HEX FLANGE
- 2 – BOLT, 1/4"-20 X 1/2", BUTTONHEAD
- 1 – BOLT, 6mm X 16mm, BUTTONHEAD
- 4 – LOCK WASHER, 1/4" TOOTHED

Application(s) >

HONDA FURY	2010-2019
SABRE	2010-2014
STATELINE	2010-2016
INTERSTATE	2010-2015

Instruction Manual >

06-0133B-SB

Page 1 of 2

Read all instructions carefully and completely before installing your new POWRFLO™ Intake.

1. Remove the (4) bolts that hold on right side air cleaner cover. Remove chrome cover and filter from air box.
2. Remove the air box by loosening the (4) screws around the air inlet. Remove those screws from the cylindrical tabs on the air box. Then remove the (1) M6 hex bolt from the lower portion of the air box. See Figure 1. The air box needs to be pulled outward to remove it from the throttle body adapter.
3. On the backside of the throttle body adapter detach the two rubber hoses by squeezing the hose clamps with a pair of pliers and sliding them past the inlets on the throttle body adapter (plug the hoses if oil drips).
4. Using a phillips screw driver loosen the throttle body adapter hose clamp that secures the throttle body adapter to the throttle body. Remove the throttle body adapter leaving the clamp attached to it.
5. Using the (4) stock screws from Step 2 and supplied lock washers, bolt together the supplied velocity stack, mounting plate, throttle spacer to the throttle body adapter in the order shown in Figure 2. Note: Apply blue Loctite® removable strength (not supplied) to stock screws before bolting together.

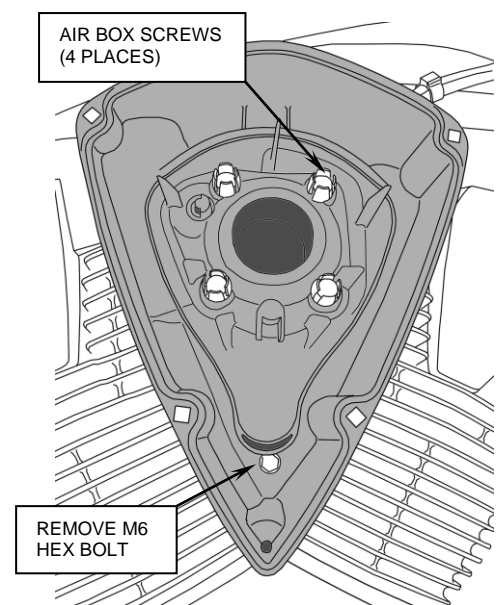
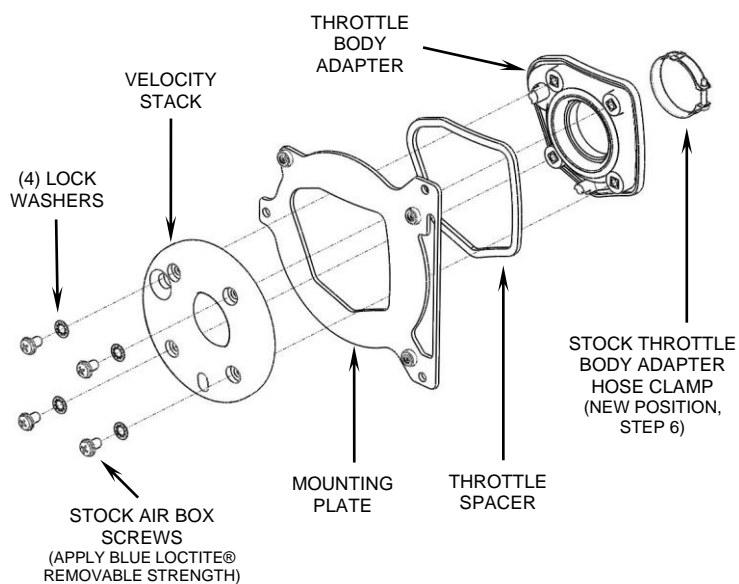
**FIGURE 1****FIGURE 2**

DISCLAIMER: NOT LEGAL FOR SALE OR USE IN CALIFORNIA ON ANY POLLUTION CONTROLLED MOTOR VEHICLE. THE SALE, USE, OR INSTALLATION OF THIS PRODUCT MAY ALSO BE ILLEGAL NATIONWIDE UNDER THE FEDERAL CLEAN AIR ACT (42 U.S.C. § 7522(A)(3)).

DOCUMENT NO. 0017 REV. A

07/22

- Remove hose clamp from rubber seal on the backside of the throttle body adapter and flip 180 degrees then reinstall onto rubber seal, then rotate the clamp 90 degrees counter-clockwise so the screw is accessible from the lower frontside of the motorcycle. See Figure 2. NOTE: the locating tab on the clamp will no longer be engaged; this is correct.
- Using (2) supplied $\frac{1}{4}$ "-20 x $\frac{1}{2}$ " buttonhead bolts, secure the fuel injector cover to the upper portion of the mounting plate, and tighten. Use a $\frac{1}{4}$ "-20 x $\frac{5}{8}$ " hex flange bolt to attach the support bracket to the lower threaded hole and orientate as shown in Figure 3, but do not tighten.
- The mounting plate assembly is ready to be attached to the motorcycle. Reattach the hoses and hose clamps that were disconnected in Step 3. Then engage the rubber seal of the throttle body adapter over the throttle body but leave the clamp loose for now.
- Between the two cylinders is a bracket with a welded nut; align the slotted hole in the support bracket with that welded nut, then insert the (1) supplied M6 x 16mm buttonhead bolt.
- Align and level the mounting plate assembly, then fully tighten the clamp over the throttle body adapter, then the bolt that secures the support bracket to the mounting plate, followed by the M6 bolt between the cylinders.
- Place the supplied venturi filter onto the velocity stack.
- Remove the intake cover from the box and insert the intake screen into place so the holes in the bent tabs align with the threaded bosses in the intake cover.
- Place intake cover over the mounting plate assembly and align the mounting holes to the threaded bosses. Insert the (3) supplied $\frac{1}{4}$ "-20 x $\frac{5}{8}$ " flange bolts and tighten the mounting plate to the intake cover. See Figure 4.

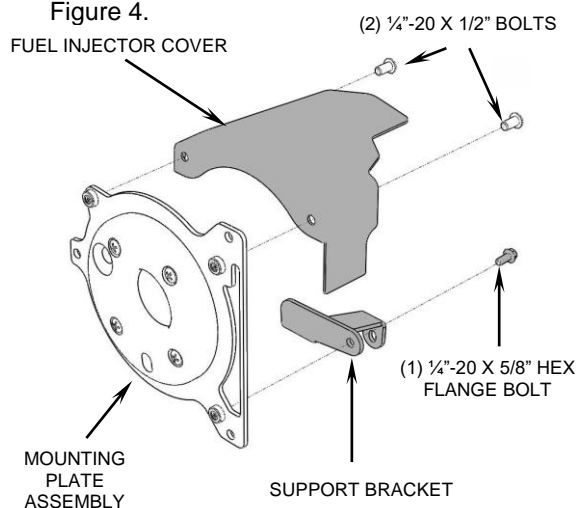
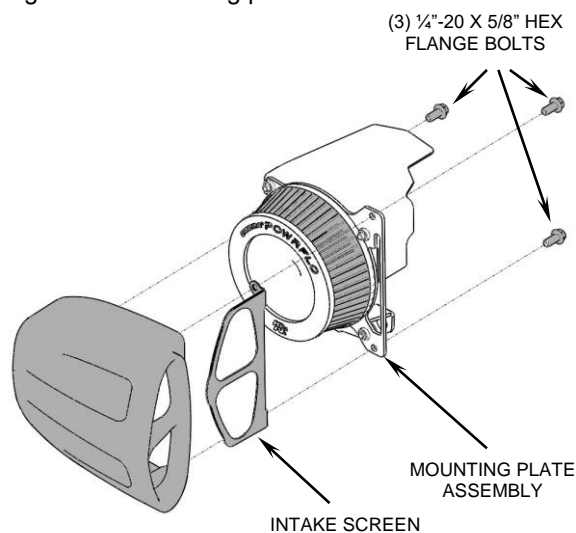
**FIGURE 3****FIGURE 4****CALIFORNIA CUSTOMERS:**

In California, aftermarket parts that have been identified specifically as replacement parts or that have received an Air Resources Board Executive Order may be used on street motorcycles. All other emissions related aftermarket parts are for competition use only. A list of replacement parts and EO parts, and corresponding fitment is provided at: www.cobrausa.com

CLEANING INSTRUCTION

To clean your black POWRFLO cover, use a liquid based soap detergent, such as dishwashing soap applied with a soft cloth and rinse with clean water. Note: Avoid abrasive cleaning methods such as granular or dry cleansers, simple green, scotch-brite or steel wool pads. Abrasives may breach the coating and shorten life.