

Items Supplied >

- 1 - INTAKE COVER
- 1 - VENTURI AIR FILTER
- 1 - INTAKE SCREEN ASSEMBLY
- 1 - BILLET VELOCITY STACK
- 1 - MOUNTING PLATE
- 1 - SUPPORT BRACKET
- 2 - BOLT, M5 X 16mm, ALLEN
- 1 - BOLT, M5 X 55mm, ALLEN; 1 - BOLT, M5 X 30mm, ALLEN (PATCH)
- 3 - BOLT, 1/4"-20 X 5/8", HEX FLANGE
- 4 - BOLT, 1/4"-20 X 1/2", BUTTONHEAD
- 4 - WASHER, 1/4" INTERNAL TOOTH LOCK
- 1 - WASHER, M5 SPLIT LOCK
- 1 - O-RING, 1.25" I.D. X .125", BUNA-N (SMALL)
- 1 - O-RING, 3.25" I.D. X .125", BUNA-N (LARGE)

Application(s) >

YAMAHA V-STAR 1300 2007-2017

Instruction Manual >

06-0245B-SB

Page 1 of 2

ATTENTION: CORRECT BOLT FITMENT IN STEP 4 REQUIRED BASED ON MODEL AND YEAR!
Read all instructions carefully and completely before installing your new POWRFLO™ Intake.

1. Remove the (4) bolts that hold on the stock air cleaner cover. Remove chrome cover and filter from air box.
2. Remove the air box by loosening the (3) allen bolts around the air inlet and the (1) M6 hex nut from the lower portion of the air box. See Figure 1. Disconnect the hose from the backside of the air box. Remove the bracket which holds the bolt that secured the M6 hex nut; reinstall bolts after the bracket has been removed.
3. Insert the supplied o-rings into the grooves of the supplied velocity stack. NOTE: Do not attempt to stretch o-rings into grooves; position o-rings evenly around groove and use gentle force (No tools) to push them in.
4. Bolt the velocity stack to the throttle body using the (2) supplied M5 x 16mm allen bolts along the top.
ATTENTION: Due to model year variation the correct length bolt must be used on the third lower bolt hole. FIRST, Use the (1) supplied M5 x 55mm allen bolt with split lock washer and try to fully tighten the bolt, if the bolt head will not seat fully and approximately 0.500" of the bolt shank still protrudes from the aluminum velocity stack, it must be removed and the supplied M5 x 30mm allen bolt with split lock washer must be installed and tightened to factory specification until fully seated. **Be absolutely sure to use the correct bolt for your model motorcycle,** Cobra will not accept responsibility for the incorrect bolt being used.
5. Position the mounting plate over the velocity stack (with the welded tube toward inside) and secure using (3) supplied 1/4"-20 x 1/2" buttonhead bolts and (3) internal tooth lock washers, finger tighten only. See Figure 3.

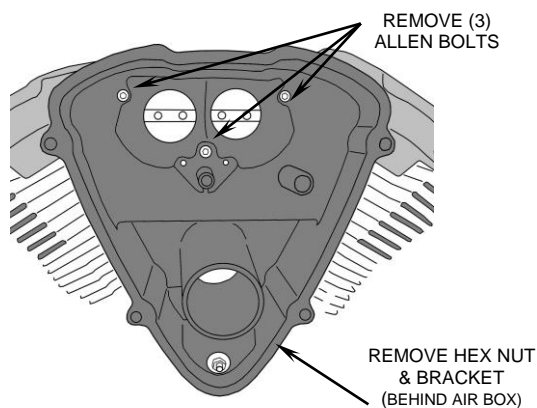

FIGURE 1

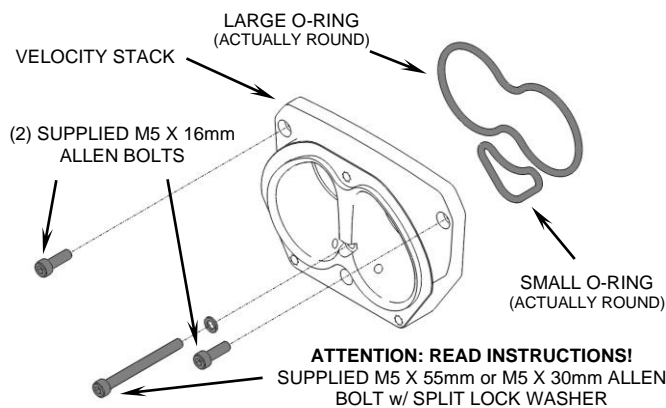
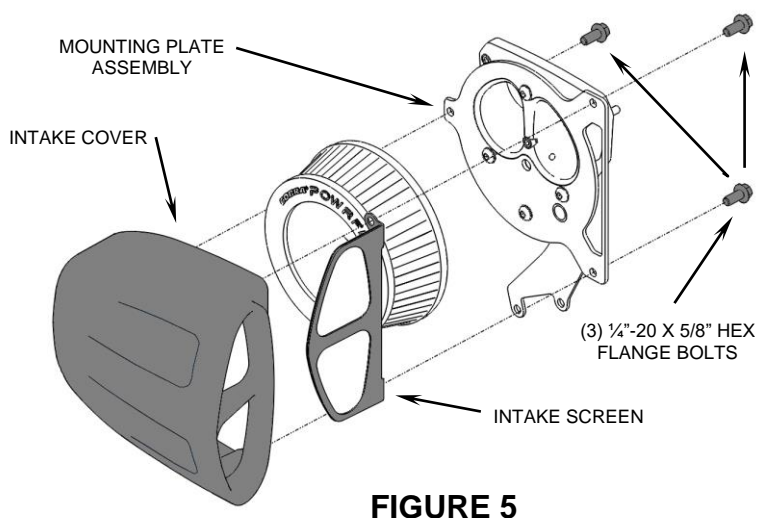
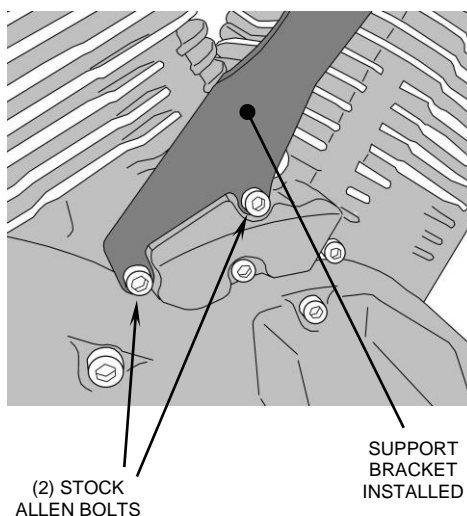
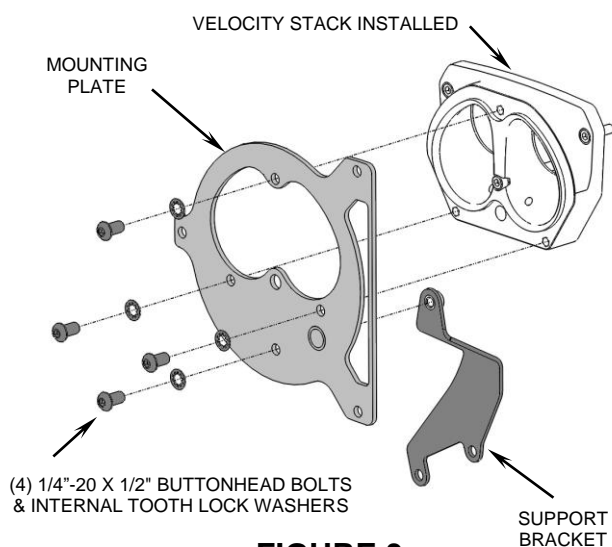

FIGURE 2

California Customers: In California, aftermarket parts that have been identified specifically as replacement parts or that have received an Air Resources Board Executive Order may be used on street motorcycles. All other emissions related aftermarket parts are for competition use only. A list of replacement parts and EO parts, and corresponding fitment is provided at: www.cobrausa.com

DISCLAIMER: NOT LEGAL FOR SALE OR USE IN CALIFORNIA ON ANY POLLUTION CONTROLLED MOTOR VEHICLE. THE SALE, USE, OR INSTALLATION OF THIS PRODUCT MAY ALSO BE ILLEGAL NATIONWIDE UNDER THE FEDERAL CLEAN AIR ACT (42 U.S.C. § 7522(A)(3)).

6. Remove the two allen bolts at the base of the cylinders and install the supplied support bracket. Secure the support bracket to the mounting plate using the (1) remaining 1/4" buttonhead bolt and internal tooth lock washer. See Figure 3 & 4.
7. Fully tighten the (4) 1/4"-20 buttonhead bolts (Steps 5 & 6) and the two stock allen bolts (Step 6).
8. Attach the hose and hose clamp that was disconnected in Step 2 to the tube on the mounting plate.
9. Insert the intake screen into place so the holes in the bent tabs align with the threaded bosses in the intake cover, see Figure 5 for orientation. Place the supplied venturi filter into the intake cover.
10. Place intake cover over the mounting plate and align the mounting holes to the threaded bosses. Insert the (3) supplied 1/4" hex flange bolts and tighten the mounting plate to the intake cover. See Figure 5.



CLEANING INSTRUCTIONS:

To clean your black POWRFLO cover, use a liquid based soap detergent, such as dishwashing soap applied with a soft cloth and rinse with clean water. **Note:** Avoid abrasive cleaning methods such as granular or dry cleansers, simple green, scotch-brite or steel wool pads. Abrasives may breach the coating and shorten life.