



Items Supplied >

- 1 – FRONT MUFFLER ASSEMBLY
- 1 – REAR MUFFLER ASSEMBLY

Application(s) >

HARLEY:	
SPORTSTER 883	14-20
SPORTSTER 1200 CUSTOM	14-20
SPORTSTER 1200 FORTY EIGHT	14-20
SPORTSTER 1200 ROADSTER	16-20

Instruction Manual >

**Read all instructions carefully and completely before installing your new slip-on mufflers**

- Loosen all heatshield clamps for clearance but do not remove the heatshields.
- Remove and save the mounting bolts that secure the mufflers to the tubular mounting bracket.
- Loosen the stock mufflers clamps. Remove the stock mufflers from the headpipes. Save the stock clamps because they will be reused.
- Slide the stock clamps over the slip-on mufflers and position them as shown in **Figure 1**.
- NOTE: THE MUFFLER WITH THE COBRA LOGO WILL ALWAYS BE THE REAR MUFFLER.** Slide the mufflers onto the headpipes (reverse the order of removal) until the mounting holes align. Fasten the mufflers using the stock mounting bolts in the same manner as stock but **do not tighten**.
- Check alignment of front and rear mufflers and make sure they are parallel. Tighten mufflers to mounting bracket. Tighten muffler clamps. (NOTE: The muffler clamps should be flush with the end of the muffler when tightened. See **Figure 2**. If the muffler clamps are slid forward past the slots on the slip collar the clamps will not tighten the mufflers properly. Also, make sure the clamp spacer is not over the slots. The slots need to be covered by the clamp band so that it seals the slots properly. Rotate the clamp if necessary).
- Align heatshields and tighten heatshield clamps. Verify that the gap, where the mufflers meet stock heatshields, is similar to the gap the stock mufflers allotted.
- Tighten any remaining loose hardware to factory specifications
- NOTE: The exhaust tips may be loosened and oriented to various positions for different visual effects.
- IMPORTANT: Before starting your engine remove all fingerprints from chrome with a quality wax or chrome polish. Failure to do so can cause chrome discoloration. Due to fluctuations in fuel delivery settings, timing, etc., Cobra Engineering does not warrant against chrome discoloration.**

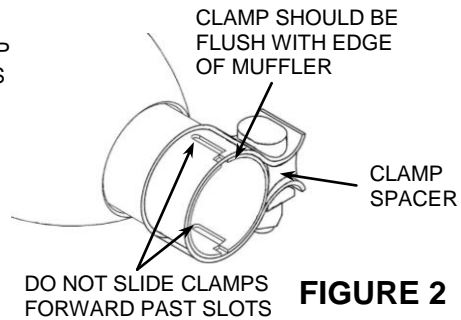
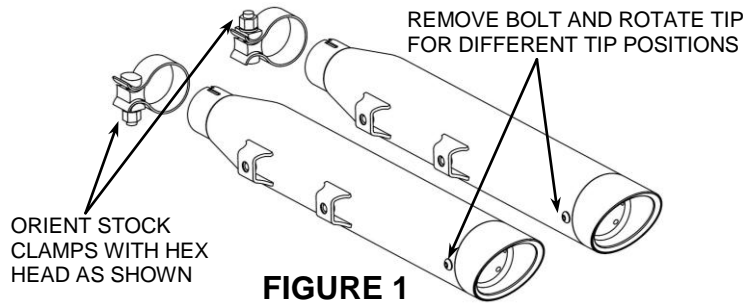

POSITION OF MUFFLERS AND MOUNTING BRACKETS SHOWN ABOVE MAY VARY FROM ACTUAL APPLICATION

REPLACEMENT E-GLASS PACKING AND OPTIONAL 1 3/4" QUIET CORES MAY BE PURCHASED THROUGH YOUR DEALER OR ONLINE AT WWW.COBRUSA.COM

DISCLAIMER: NOT LEGAL FOR SALE OR USE IN CALIFORNIA ON ANY POLLUTION CONTROLLED MOTOR VEHICLE. THE SALE, USE, OR INSTALLATION OF THIS PRODUCT MAY ALSO BE ILLEGAL NATIONWIDE UNDER THE FEDERAL CLEAN AIR ACT (42 U.S.C. § 7522(A)(3)).