

Items Supplied >

- 1 - FRONT HEADPIPE W/ HEATSHIELD
- 1 - REAR HEADPIPE/MUFFLER ASSEMBLY W/ HEATSHIELD
- 1 - BRACKET, EXHAUST MOUNT
- 6 - CLAMP, HS-24
- 1 - CLAMP, 27-61MSC
- 2 - BOLT, 5/16" X 1/2" FLANGE W/ LOCK PATCH

Application(s) >

HARLEY:

SPORTSTER 883	07-13
SPORTSTER 883 CUSTOM	09-13
SPORTSTER 883 IRON	09-13
SPORTSTER 883 SUPERLOW	07-13
SPORTSTER 1200 CUSTOM	07-13
SPORTSTER 1200 NIGHTSTER	07-12
SPORTSTER 1200 ROADSTER	07-08
SPORTSTER 1200 SUPERLOW	07-11
SPORTSTER 1200 FORTY EIGHT	10-13

Instruction Manual >

6461B

Page 1 of 3

PRIOR TO INSTALLATION, MAKE SURE YOUR STOCK HEADPIPE GASKETS ARE IN GOOD CONDITION. IF YOU HAVE ANY DOUBTS AS TO THEIR CONDITION, REPLACE THEM.

Read all instructions carefully and completely before installing your new exhaust system!

SPECIAL NOTE: This system does not work in combination with rear passenger foot pegs.

1. Unplug O₂ sensors on front and rear headpipes from motorcycle wire harnesses.
2. Remove the stock exhaust system being careful not to damage the headpipe gaskets. If the headpipe gaskets are in good condition they do not need to be removed from the cylinders. Remove and save the flanges, nuts, retaining rings and O₂ sensors from the stock exhaust. Also, remove the rear passenger foot pegs and mounting brackets since they will not fit with this system.
3. Remove the sprocket cover. You will need to remove the foot peg mount to gain clearance to remove the sprocket cover.
4. Remove the stock exhaust mount bracket.
5. Install the supplied exhaust mount bracket using the stock bolts. See **FIGURE 1**. Tighten the bolts to factory specifications.
6. Reinstall the sprocket cover and foot peg mount. Tighten to factory specifications.



FIGURE 1
Continued on Page 2

*** Cobra® recommends you always wear a helmet while riding. Please never operate your motorcycle while under the influence of alcohol and/or drugs. Enjoy the new look of your motorcycle and please ride safely.**

7. Install the stock flanges, retaining rings and O₂ sensors onto the supplied front and rear headpipes.
8. Install the front headpipe (with stock gasket in place) onto the front cylinder using the stock nuts. Snug the nuts but **DO NOT TIGHTEN** at this time.
9. Position the supplied #27-61 MSC clamp with hex head facing inward and down as shown in **FIGURE 2** and slide onto the muffler assembly inlet.
10. Install the rear headpipe and muffler assembly (with stock gasket in place) onto the rear cylinder and slide the muffler assembly inlet on to the front headpipe. Use the stock nuts to fasten the headpipe to the cylinder. Snug the nuts but **DO NOT TIGHTEN** at this time. Make sure the front headpipe is pushed in as far as possible into the muffler assembly inlet. Secure the muffler assembly to the exhaust mount bracket using the (2) supplied 5/16"-18 bolts. Snug the bolts to hold the muffler assembly in position but **DO NOT TIGHTEN**.
11. Make sure the muffler assembly and front headpipe are straight and tighten in the following order; headpipe flanges to the cylinders (slowly tightening opposing nuts), muffler assembly to the exhaust mount and finally the muffler assembly inlet clamp. (NOTE: The clamp should be flush with the end of the muffler assembly inlet when tightened. See **FIGURE 2**. If the clamp is slid past the slots on the muffler assembly inlet the clamp will not tighten properly).

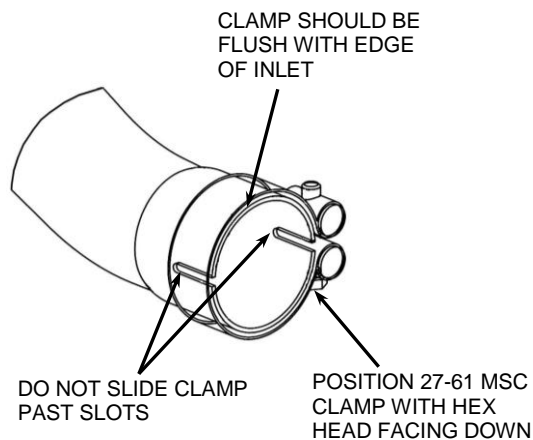
**FIGURE 2**

12. Plug the O₂ sensors back into motorcycle wire harnesses.
13. Unscrew the **HS-24** clamps and feed the tail end of the clamp through the clips on the inside of the heatshields. See **FIGURE 3** for proper positioning of the clamps on the heatshields. (NOTE: The arrows point to the positioning of the hex head of the clamps. The hex head of the clamps should be accessible for tightening but not visible when heatshields are mounted to the pipes.)
14. Install the front heatshield first. (NOTE: Spread the hose clamps apart slightly to make it easier to slide them over the headpipes.) Make sure the muffler assembly clamp does not interfere with the heatshield and is aligned as shown in **FIGURE 2**. Snug the heatshield clamps but do not tighten.
15. Install the rear heatshield the same way as the front heatshield. See **FIGURE 3**. The rear heatshield should go on top of the front heatshield at the collector area.

Continued on Page 3

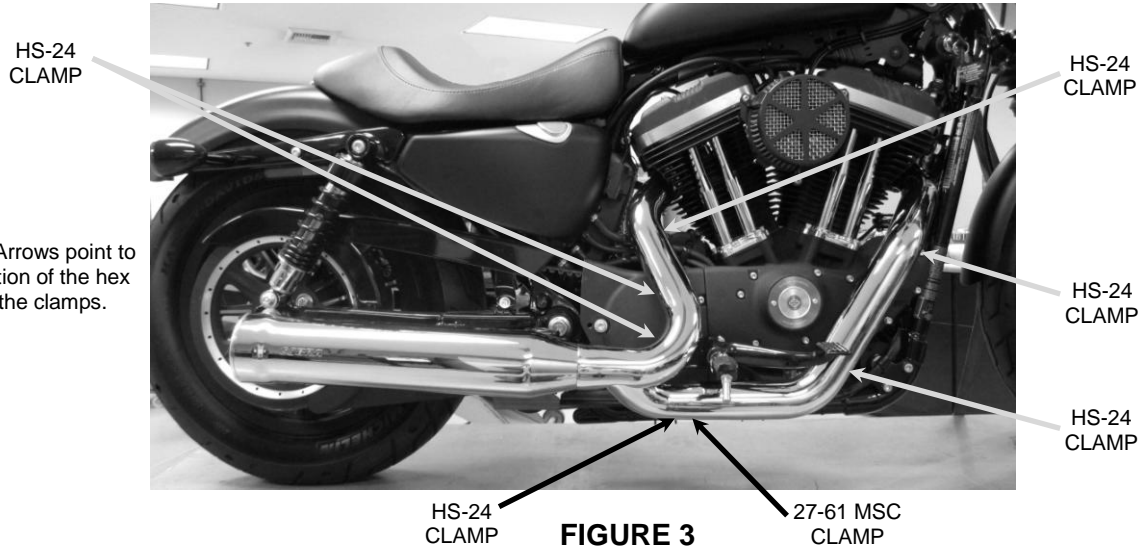

NOTE: Arrows point to the position of the hex head of the clamps.

17. Make sure the heatshields are straight and that there is a small gap at the end of the rear heatshield and the front of the muffler body so that it will not scratch the plating and eventually rust. Then tighten the clamps on the heatshields.
18. Make sure all the hardware (brackets, headpipes, heatshield clamps, muffler assembly inlet clamp) has been tightened appropriately.
19. **IMPORTANT:** Before starting your engine remove all fingerprints from all exhaust surfaces. To clean your black exhaust system use a liquid based soap detergent, such as dishwashing soap applied with a soft cloth and rinse with clean water. Note: Avoid abrasive cleaning methods such as granular or dry cleansers, simple green, scotch-brite or steel wool pads. Abrasives may breach the coating and shorten life.

IMPORTANT: It is recommended that a Cobra Fi2000® Closed Loop Digital Fuel Processor (**Part#: 692-1620AT & 692-1620CL; CA state models use Part#: 692-1620CL-50**) be installed with the Cobra exhaust system. www.fi2000r.com.

California does not allow the use of aftermarket exhaust systems that remove original equipment catalysts, (except for racing use only) unless the Air Resources Board has issued an Executive Order for that system.