

Items Supplied >

- 1 - FRONT HEADPIPE W/ HEATSHIELD
- 1 - REAR HEADPIPE/MUFFLER ASSEMBLY W/ HEATSHIELD
- 2 - CORE WITH CHROME TIP
- 2 - 1/4" X 1/2" BUTTON HEAD BOLTS
- 2 - 1/4" FLAT WASHERS
- 1 - BRACKET, EXHAUST MOUNT
- 4 - CLAMP, HS-24 (SMALL)
- 1 - CLAMP, 27-61MSC
- 2 - BOLT, 5/16" X 5/8" FLANGE W/ LOCK PATCH
- 1 - SPACER, .750"O.D. X .343" I.D. X .550" L BLACK
- 2 - SPACER, ALUMINUM .550"O.D. X .344" I.D. X .170" L
- 1 - SPACER, RIGHT FOOTPEG MOUNT

Application(s) >

- HARLEY:
- | | |
|------------|-------|
| DYNA | 12-17 |
| SWITCHBACK | 12-16 |

Instruction Manual >

6708B

Page 1 of 3

PRIOR TO INSTALLATION, MAKE SURE YOUR STOCK HEADPIPE GASKETS ARE IN GOOD CONDITION. IF YOU HAVE ANY DOUBTS AS TO THEIR CONDITION, REPLACE THEM.

Read all instructions carefully and completely before installing your new exhaust system!

1. Apply masking tape to any surrounding parts to protect them from getting scratched.
2. For Switchback models, the right side floorboard will need to be removed from the mounts. Also remove the forward mount bolt and loosen the rearward mount bolt so the mount will swing out of the way for clearance.
3. Unplug O₂ sensors on front and rear headpipes from motorcycle wire harnesses.
4. Remove the stock exhaust system being careful not to damage the headpipe gaskets. If the headpipe gaskets are in good condition they do not need to be removed from the cylinders. Remove and save the flanges, nuts, retaining rings and O₂ sensors from the stock exhaust.
5. Remove the stock exhaust mount bracket.
6. Remove the two lower bolts on the right foot peg mount. See **FIGURE 3**. Insert the supplied foot peg spacer between the frame and the foot peg mount and then reinstall the bolts. Tighten the bolts to factory specifications. See **FIGURE 3**.
7. Install the supplied exhaust mount bracket using the stock bolts. See **FIGURE 1**. Tighten the bolts to factory specifications. If applicable, be sure to insert the large spacer between the exhaust mount and the transmission case as shown in **FIGURE 1**. For Switchback models, also insert 2 of the supplied small aluminum spacers into the large holes in the exhaust mount bracket as shown in **FIGURE 2**.

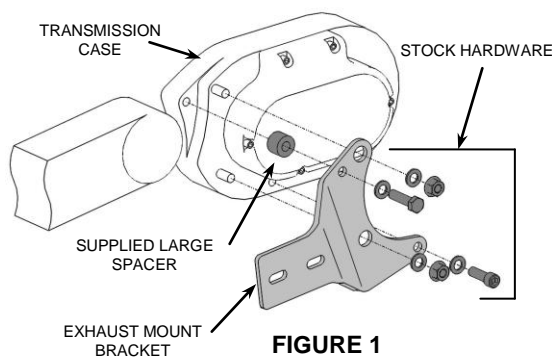

FIGURE 1
DYNA

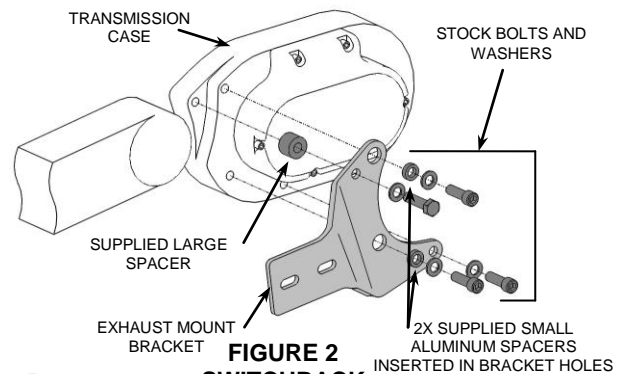

FIGURE 2
SWITCHBACK

Continued on Page 2

DISCLAIMER: NOT LEGAL FOR SALE OR USE IN CALIFORNIA ON ANY POLLUTION CONTROLLED MOTOR VEHICLE. THE SALE, USE, OR INSTALLATION OF THIS PRODUCT MAY ALSO BE ILLEGAL NATIONWIDE UNDER THE FEDERAL CLEAN AIR ACT (42 U.S.C. § 7522(A)(3)).

7. Unwrap the heatshields and headpipes from packaging. Leave the rear heatshield on the rear headpipe and muffler assembly.
8. Install the stock flanges, retaining rings and O₂ sensors onto the supplied front and rear headpipes.
9. Unscrew the **HS-24** clamps and feed the tail end of the clamp through the clips on the inside of the heatshields. See **FIGURE 4** for proper positioning of the clamps on the heatshields. (NOTE: The arrows point to the positioning of the hex head of the clamps. The hex head of the clamps should be accessible for tightening but not visible when heatshields are mounted to the pipes.) Leave the rear heatshield clamps loose. **DO NOT TIGHTEN** at this time.
10. Install the front headpipe (with stock gasket in place) onto the front cylinder using the stock nuts but **DO NOT TIGHTEN** at this time.
11. Position the supplied #27-61 MSC muffler clamp with hex head facing the direction shown in **FIGURE 3** and slide onto the rear muffler inlet tube.
12. Install the rear headpipe, heatshield, and muffler assembly (with stock gasket in place) onto the rear cylinder and slide the lower muffler inlet on to the front headpipe. Use the stock nuts to fasten the rear headpipe to the cylinder but **DO NOT TIGHTEN** at this time. Make sure the front headpipe is pushed in as far as possible into the rear muffler slip.
13. Secure the muffler assembly to the exhaust mount bracket using the (2) supplied 5/16"-18 bolts but **DO NOT TIGHTEN**.
14. Make sure the rear muffler assembly and front headpipe are straight and parallel and tighten in the following order; headpipe flanges to the cylinders (slowly tightening opposing nuts), muffler assembly to the exhaust mount and finally the muffler clamp. (NOTE: The muffler clamps should be flush with the end of the muffler inlet when tightened. See **FIGURE 3**. If the muffler clamp is slid past the slots on the muffler inlet the clamp will not tighten properly).

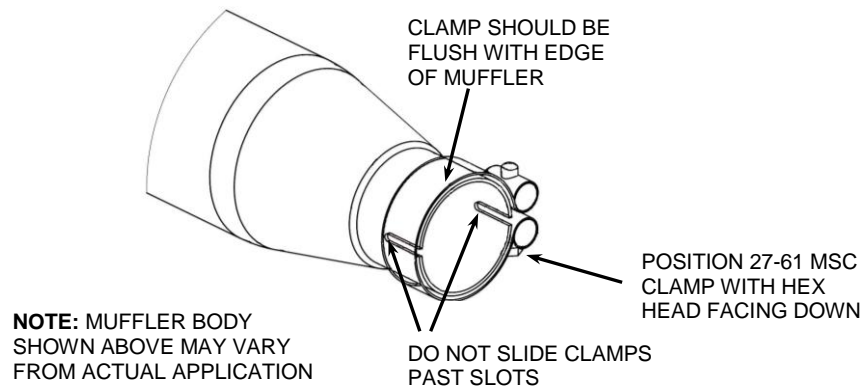

FIGURE 3

15. Plug the O₂ sensors back into motorcycle wire harnesses.
16. Install the front heatshield. Slide the rear portion of the heatshield forward over the muffler while gently pushing the front of the heatshield into place between the frame and motor (NOTE: Spread the hose clamps apart slightly to make it easier to slide them over the muffler assembly and headpipes.) Make sure the muffler clamp does not interfere with the heatshield and is aligned as shown in **FIGURE 3**.
17. Snug all of the front and rear heatshield clamps but do not tighten.
18. Insert the cores into the muffler bodies and align the threaded hole in the core tip with the hole in the heatshield and muffler body. See **FIGURE 5**. (NOTE: If it is difficult to align the heatshield, muffler body, and core then loosen the clamps on the heatshields so the heatshields can move forward or backward.)

Continued on Page 3

HS-24
CLAMP

NOTE: Arrows point to the position of the hex head of the clamps.



HS-24
CLAMP

HS-24
CLAMP

FIGURE 3

INSTALL
SUPPLIED FOOT
PEG SPACER

HS-24
CLAMP

19. Insert the supplied ¼-20 button head screws and 1/4" flat washers through the heatshield and muffler body into the threaded hole in the core tips and snug the screws. Do not tighten at this time. See **FIGURE 5**.

FASTEN CORES
WITH SUPPLIED
¼-20 BUTTON HEAD
SCREWS AND FLAT
WASHERS

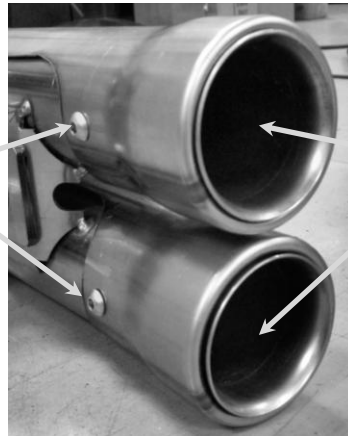

INSERT CORES INTO
MUFFLER BODIES

FIGURE 5

20. Make sure the ends of both core tips and heatshields are flush vertically with each other and tighten the clamps on the heatshields. Then tighten the screws for the core tips.
21. Make sure all the hardware (brackets, headpipes, heatshields, and tips) have been tightened appropriately.
22. **IMPORTANT:** Before starting your engine remove all fingerprints from all exhaust surfaces. To clean your black exhaust system use a liquid based soap detergent, such as dishwashing soap applied with a soft cloth and rinse with clean water. Note: Avoid abrasive cleaning methods such as granular or dry cleansers, simple green, scotch-brite or steel wool pads. Abrasives may breach the coating and shorten life.