

Items Supplied >

2 – FRONT & REAR EXHAUST HEADPIPE / HEATSHIELD ASSEMBLY
1 – MUFFLER ASSEMBLY
1 – EXHAUST MOUNT BRACKET
4 – CLAMPS HS-24
2 – CLAMPS HS-28
2 – CLAMPS 27-61 MSC
2 – BOLT, HEX 5/16-18 x 5/8"
2 – BOLT, HEX 3/8 x 3/4"
2 – EXHAUST TIPS
2 – BOLT, BUTTONHEAD ALLEN 1/4" X 3/8"

Application(s) >

HARLEY ROCKER

2008-2010

Instruction Manual >

6765 / 6865

Page 1 of 2

PRIOR TO INSTALLATION, MAKE SURE YOUR STOCK HEADPIPE GASKETS ARE IN GOOD SHAPE. IF YOU HAVE ANY DOUBTS AS TO THEIR CONDITION, REPLACE THEM.

Read all instructions carefully and completely before installing your new exhaust system

1. Unbolt the seat and remove the plastic battery cover. Disconnect the positive and negative battery terminals and remove battery from motorcycle.
2. To remove the rear O₂ sensor remove the plastic push rivet located under the battery. See Figure 1. This will release the O₂ sensor connector under the oil tank. Unplug the factory O₂ connector from wiring harness.
3. On the front of the motorcycle remove the 2 Allen bolts that secure the voltage regulator bracket to the frame, and remove the rectangular cover over the top of this bracket. Ease the voltage regulator forward just enough to unplug the front O₂ connector.
4. Remove stock exhaust system. Retain the stock 5/16" flange nuts for use later during reassembly.
5. Remove the flanges, retaining rings and O₂ sensors from the stock headpipes.
6. Place the exhaust mount bracket on the motorcycle and bolt into place using the supplied 3/8" bolts. See Figure 2. **DO NOT FULLY TIGHTEN.**
7. Remove the front and rear headpipes from box and install stock flanges, retaining rings and O₂ sensors onto pipes.
8. Install the front and rear headpipes on the motorcycle using the stock 5/16" flange nuts but do not tighten.
9. Remove the muffler assembly from the box and slide one supplied T-clamp #27-61MSC onto each muffler tube. Refer to Figure 3 for proper alignment.
10. Slide the muffler assembly onto the head pipes by tapping on the head pipes with your hand as you push the muffler forward making sure the assembly slides as far forward as possible. Secure the muffler assembly to the mounting bracket using the supplied 5/16 bolts but **do not tighten.**

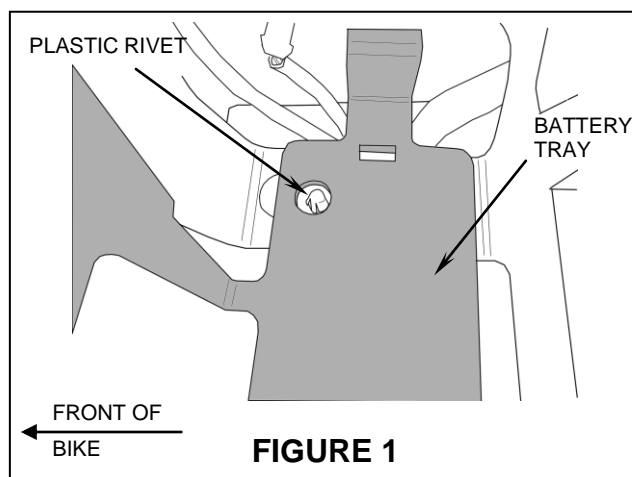

* Cobra® recommends you always wear a helmet while riding. Please never operate your motorcycle while under the influence of alcohol and/or drugs. Enjoy the new look of your motorcycle and please ride safely.

11. Make sure the muffler assembly is parallel with the head pipes (this is critical) then tighten the following in order, muffler bracket to the frame, muffler assembly to the muffler bracket, head pipe flanges to the motor (slowly tighten opposing nut) and muffler clamps. (NOTE: If the muffler clamps are slid to far up the muffler or past the two slots, the clamps will not tighten.)
12. Plug the rear O₂ sensors back into motorcycle wire harness and reinstall the plastic push rivet removed in Step 2 into the original location. Reinstall front O₂ connector then tighten voltage regulator bracket bolts to factory specifications.
13. Unscrew the remaining hose clamps and feed the tail end of the clamp through the clips on the inside of the heat shields. The screw end of the hose clamp should be accessible for tightening but not visible when the heat shields are mounted to the pipes. The larger HS-28 clamps go to the rear of the heatshields over the muffler bodies.
14. To install the front heatshield, first slide the rear portion of the heatshield over the muffler, continue to slowly slide it forward pushing the front of the shield gently into place between the frame and motor (Hint: Spread the hose clamps apart slightly to make it easier to slide them over the muffler assembly and head pipes). Make sure the muffler clamps don't interfere with the heatshields and are aligned as shown in Figure 3. Snug the heatshield clamps but do not tighten.
15. Install the rear heatshield the same way as the front heatshield.
16. Install one billet tip on each heatshield making sure the ends of the tips are parallel with each other. Fasten the tips with the supplied ¼-20 screws making sure they snug up against the heatshield leaving no gap between the tip and heatshield when tighten. **If it is difficult to slide the tips into the heatshields loosen the clamps on the heatshield, failure to do this may cause damage to the chrome tips.**
17. Tighten all clamps on both heatshields.
18. Make sure all the hardware (brackets, headpipes, heatshields, mufflers and baffles) have been tightened appropriately and cleaned before starting your motorcycle.

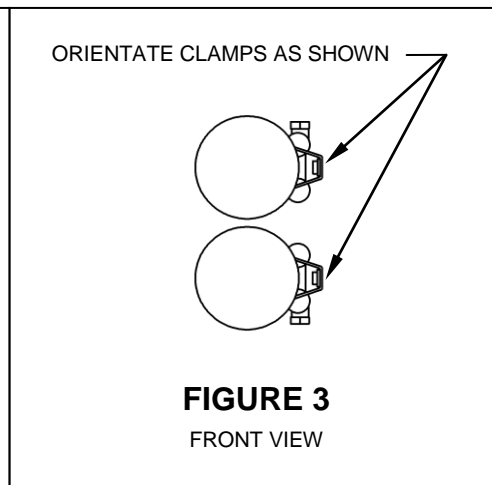
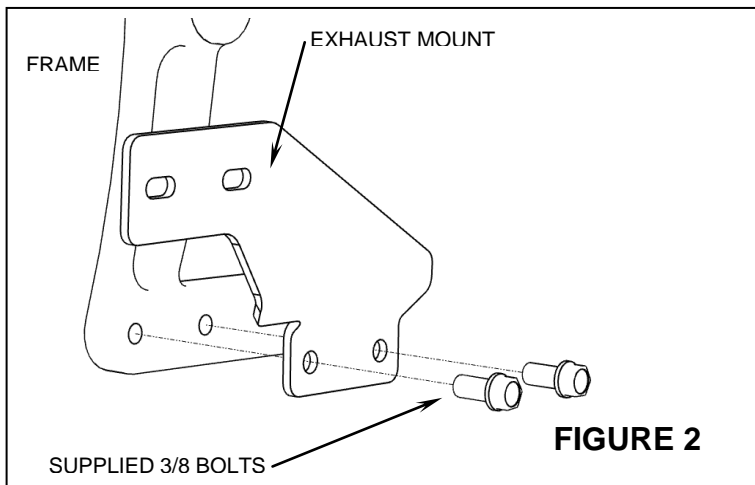

IMPORTANT: Your motorcycle is equipped with fuel injection; it is recommended that you install a Cobra Fi2000® Digital Fuel Processor with your Cobra exhaust system. **Cobra Part #: 692-1611CL.** Cobra is not responsible for the performance of any other fuel management system used with Cobra exhaust systems.

California does not allow the use of aftermarket exhaust systems that remove original equipment catalyts, (except for racing use only) unless the Air Resources Board has issued an Executive Order for that system.