

Items Supplied >

- 2 – CHROMED FREEWAY BAR (1 LEFT & 1 RIGHT)
- 2 – CLAMP, BILLET ALUMINUM
- 1 – CROSSOVER BRACKET
- 2 – BOLT, HEX FLANGE M8 X 16 mm, W / LOCK PATCH
- 4 – BOLT, HEX FLANGE 5/16"-18 X 5/8"
- 2 – SPACER, BLACK POWDERCOATED

Application(s) >

HONDA SHADOW RS 2010-2014

Instruction Manual >

01-1114

Page 1 of 1

Read all instructions carefully before installing your new Cobra® product

1. Remove the front M10 bolt from the right footpeg mount and set aside. Loosen, but do not remove the rear M10 bolt from the right footpeg mount.
2. Slide the right side freeway bar's lower mounting bracket between the footpeg mount and frame and align the hole. Start threading the front M10 bolt removed in Step 1 through the footpeg mount, freeway bar and into the frame but leave loose for now. See Figure 1.
3. Rotate top of freeway bar towards the frame. Install the supplied billet clamp onto the right frame tube and thread the supplied 5/16"-18 hex bolts through the upper mount and into the clamp, leaving them loose. See Figure 2.
4. Remove the rear M10 bolt, loosened in Step 1, from the right footpeg mount. Place a supplied spacer between the frame and the footpeg mount then re-insert the M10 bolt and snug. See Figure 1.
5. Repeat Steps 1-4 on left side. NOTE: Be careful not to pinch any wires with the upper mount or billet clamp.
6. Using the supplied M8 bolts install the crossover bracket between the lower mounts. See Figure 1.
7. Tighten all bolts starting with the 5/16"-18 hex bolts making sure clamps do not rotate and stay seated against frame tube. Next fully tighten the M10 footpeg mounting bolts, followed by the M8 bolts securing the crossover bracket. Torque all bolts to there appropriate values.

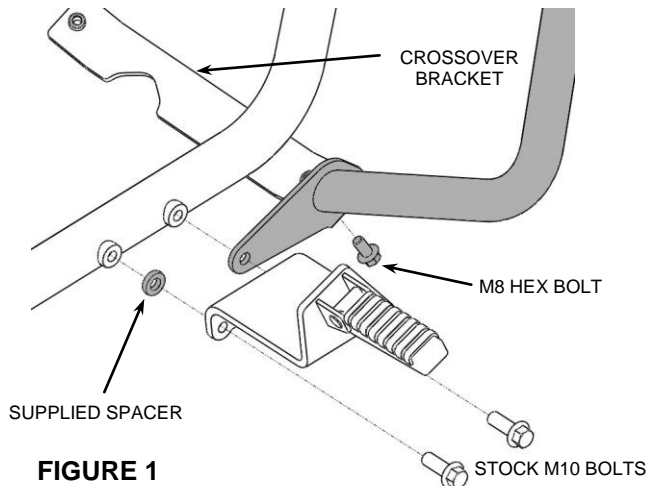

FIGURE 1
(RIGHT SIDE SHOWN)

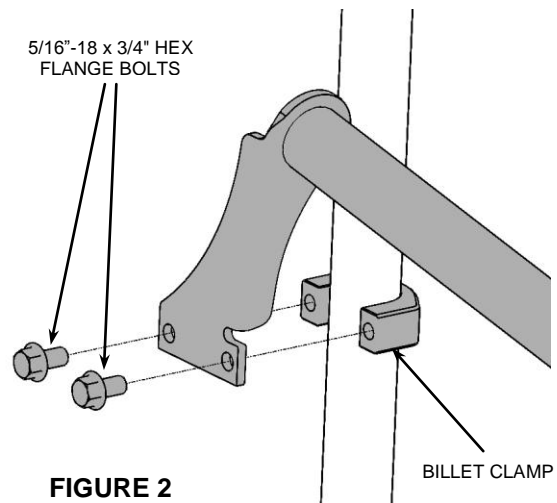

FIGURE 2
(RIGHT SIDE SHOWN)

Cobra Freeway Bars add style to your motorcycle. They are not designed to withstand a serious impact and may not protect you and/or your motorcycle in the event of a crash.

*** Cobra® recommends you always wear a helmet while riding. Please never operate your motorcycle while under the influence of alcohol and/or drugs. Enjoy the new look of your motorcycle and please ride safely.**