

## Items Supplied >

- 1 – DETACHABLE SOLO TOUR PACK MOUNT
- 4 – BOLT, HEX ¼”-20 X 1” ZINC
- 4 – NUT, HEX NYLOCK ¼” ZINC
- 8 – WASHER, FLAT ¼”

## Application(s) >

HARLEY:  
DRESSER 2009 - 2013

## Instruction Manual >

602-2703

Page 1 of 2

**Read all instructions, including the instructions for the Tour-Pack to be installed, carefully and completely before installing your new Tour Pack!**

**NOTE:** You must install either a **COBRA Mounting Kit (602-2100/602-2101)** or a Harley Davidson 4 point Mounting Kit before installing this mount.

### Initial Installation of Tour Pack to Tour Pack mount:

1. Open the Tour Pack and carefully remove any contents, as well as the rubber mat or other map pocket / liner covering the mounting plate on the bottom surface. Determine if the Tour Pack will be mounted in the forward or rearward position on the Tour Pack mount, see **FIGURE 1**. There are two sets of holes in the Tour Pack mounting plate, Set “A” is the rearward set, Set “B” is the forward set.

**NOTE:** We recommend having someone assist you with the next steps, to prevent scratching the Tour Pack, mount, or motorcycle.

2. With the Tour Pack lid open, align the desired holes (A or B) in the Tour Pack with the holes in the Tour Pack mount.
3. From the inside of the Tour Pack, insert each supplied ¼”-20 X 1” hex bolt (1) through a supplied ¼” washer (2), the chosen set of holes (A or B) in the Tour Pack and it's mounting plate, the supplied Tour Pack mount (3), a second supplied ¼” washer (2), and finally a supplied ¼”-20 hex nylock nut (4), see **FIGURE 2 / TABLE 1**. Tighten the nuts (4) in a cross pattern from the bottom of the Tour Pack mount to a **TORQUE of 120 in\*lbs**. Secure the Tour Pack mounting plate to the Tour Pack plastic bottom per the instructions of the Tour Pack.

**NOTE:** Ensure that the screws are installed from the top and from the inside of the Tour Pack, to prevent the screws from tearing the liner or scratching any objects inside the Tour Pack during use.

### Tour Pack mount attachment to mounting kit procedure:

4. Once the Tour Pack and mount have been assembled you can attach the Tour Pack to the mounting kit on the motorcycle by inserting the front portions of the mount brackets over the mounting bosses on the inner sides of the rear motorcycle shock mount. See **FIGURE 3**. Make sure to insert the mount all the way onto the bosses.
5. Slowly rotate the mount downward so the rear portion of the brackets slips over the forward mounting kit bushings. See **FIGURE 3**.
6. If you are using a Harley Mounting Kit, you may need to adjust the width of the mounting kit bushings with spacers in order for them to align with the width of the Tour Pack mount brackets. Please see the instructions that come with the mounting kit for more details.

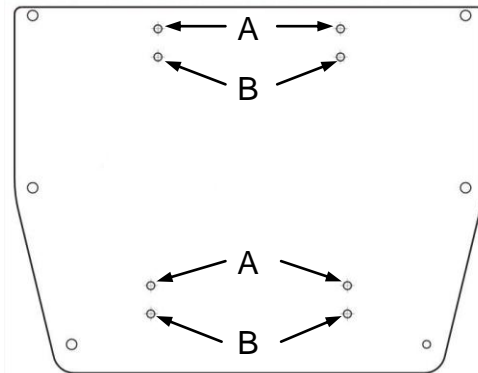
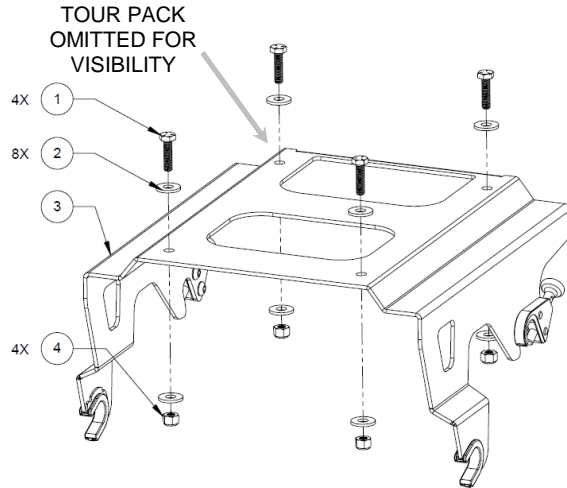

**FIGURE 1, TOUR PACK MOUNTING PLATE HOLE LOCATIONS**

**CONTINUED ON PAGE 2**

**\* Cobra® recommends you always wear a helmet while riding. Please never operate your motorcycle while under the influence of alcohol and/or drugs. Enjoy the new look of your motorcycle and please ride safely.**

9. Also, some Harley Mounting Kits come with oval shaped mounting bushings. These mounting bushings may need to be rotated around the center axis of the bushing to allow for a secure fit of the detachable latch pin. Please see the instructions of the mounting kit for more details.
10. Pull backward on both detachable latch knobs and then push downward on the Tour Pack to allow the mount to sit completely on the mounting kit bushings. Then release the detachable latch knob to fully engage the latch pin underneath the mounting kit bushing. See **FIGURE 3**.
11. Always check to make sure both detachable latch pins are fully engaged on the bottom of the mounting kit bushing.
12. Remove the saddle bags per the instructions in the Owner's Manual, and make any adjustments to the mounting kit bushings until the detachable rack goes on and off easily and securely.
13. Once all the adjustments have been made, verify all hardware has been tightened and reinstall the saddle bags.
14. Before each ride, check to make sure the detachable latch pins are fully engaged underneath the mounting bushings.
15. Check the tightness of all the screws after the first ride and after the first 500 miles.



**FIGURE 2, HARDWARE INSTALLATION**

ITEM	DESCRIPTION	QUANTITY
1	1/4-20 X 1" HEX HEAD SCREW	4
2	1/4" I.D. WASHER	8
3	TOUR PACK MOUNT	1
4	1/4-20 NYLOCK NUT	4

**TABLE 1, HARDWARE REFERENCE**



**FIGURE 3, TOUR PACK MOUNT INSTALLED**

**\*\*\* DO NOT \*\*\* EXCEED THE MAXIMUM WEIGHT CAPACITY OF THE TOUR PACK MOUNT, MAX. WEIGHT CAPACITY INCLUDES TOUR PACK AND CONTENTS = 25 POUNDS.**