

Items Supplied >

- 1 – FRONT HEADPIPE
- 1 – FRONT HEATSHIELD
- 1 – REAR HEADPIPE / MUFFLER ASSEMBLY
- 1 – REAR HEATSHIELD
- 1 – EXHAUST MOUNT BRACKET
- 3 – HOSE CLAMPS HS-24
- 2 – HOSE CLAMPS HS-28
- 1 – CLAMP, 27-61MSC
- 2 – BOLT, 5/16"-18 x 5/8" HEX FLANGE W/ LOCK PATCH
- 2 – BOLT, 3/8"-16 x 3/4" HEX FLANGE W/ LOCK PATCH

Application(s) >

HARLEY:	
FXS	2011-13
FLS	2012-17
FLSTF	2012-17
FLSTFB	2012-16
FLSTN	2012-17
FLSTC	2012-17

Instruction Manual >

6225

Page 1 of 2

PRIOR TO INSTALLATION, MAKE SURE YOUR STOCK HEADPIPE GASKETS ARE IN GOOD SHAPE. IF YOU HAVE ANY DOUBTS AS TO THEIR CONDITION, REPLACE THEM.

Read all instructions carefully and completely before installing your new exhaust system

1. Unplug O₂ sensors on front and rear headpipes from motorcycle wire harnesses. Remove stock exhaust system. Remove and save the flanges, flange nuts, retaining rings and O₂ sensors from the stock headpipes.
2. Remove the two right floorboard/rear brake lever mount bolts leaving the third in place, but loosen and rotate mount down out of the way. See Figure 1. This will make installation of exhaust and heatshields possible.
3. Install the exhaust mount bracket on the motorcycle using the two supplied 3/8" bolts. See Figure 2. **DO NOT TIGHTEN.**
4. Remove the flanges, retaining rings and O₂ sensors from the stock headpipes and install on Cobra headpipes. Leave stock gaskets in the cylinders but check their condition and replace if needed.
5. Install the front headpipe onto the front cylinder using two stock nuts from Step 1. **DO NOT TIGHTEN** at this time.

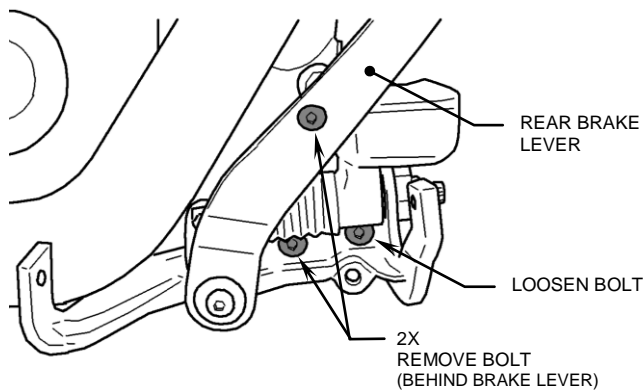

FIGURE 1

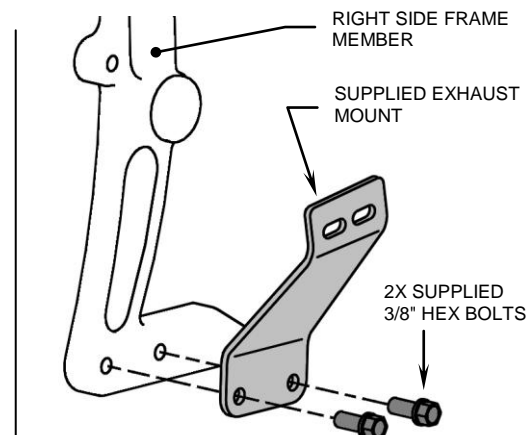

FIGURE 2

DISCLAIMER: NOT LEGAL FOR SALE OR USE IN CALIFORNIA ON ANY POLLUTION CONTROLLED MOTOR VEHICLE. THE SALE, USE, OR INSTALLATION OF THIS PRODUCT MAY ALSO BE ILLEGAL NATIONWIDE UNDER THE FEDERAL CLEAN AIR ACT (42 U.S.C. § 7522(A)(3)).

6. Place the supplied 27-61msc clamp onto the lower muffler inlet then slide the rear headpipe / muffler assembly onto the front headpipe and into the rear exhaust port. Bolt rear headpipe onto the rear cylinder using the stock nuts from Step 1 but **DO NOT TIGHTEN**. See Figure 3 for clamp orientation.
7. Bolt the muffler assembly to the exhaust mount using the supplied 5/16" bolts. **DO NOT TIGHTEN**.
8. Make sure the front headpipe is inserted properly into the rear assembly. Tighten the following in order; exhaust mount to the frame, then the flange nuts securing the exhaust flanges (slowly tighten opposing nuts), followed by the muffler to the exhaust mount. Tighten the 27-61msc clamp last. (NOTE: If the muffler clamp is slid past the slots on the muffler slip the clamp will not tighten properly)
9. Plug O₂ sensor connectors back into motorcycle wire harnesses.
10. Unscrew all supplied hose clamps and feed the tail end of the clamp through the clips on the inside of the heatshields; the larger clamps go to the rear of the heatshields where they will rest on the muffler bodies, smaller ones to the front for the headpipes. The screw end of the hose clamp should be accessible for tightening but not visible when heatshields are mounted to the pipes, see Figure 4.
11. To install the front heatshield, first slide the rear portion of the heatshield over the muffler, continue to slowly slide it forward pushing the front of the shield gently into place between the frame and motor (Hint: Spread the hose clamps apart slightly to make it easier to slide them over the muffler assembly and headpipes). Make sure the muffler clamp doesn't interfere with the heatshields and is aligned as shown in Figure 3. Snug the heatshield clamps but **DO NOT TIGHTEN**.
12. Install the rear heatshield in the same manner as the front heatshield. Make sure heatshields are properly aligned then tighten all hose clamps.
13. Reinstall the right side footpeg/floorboard and tighten bolts to factory specifications.
14. Make sure all the hardware (brackets, headpipes, heatshields, and mufflers) has been tightened appropriately and cleaned before starting your motorcycle.

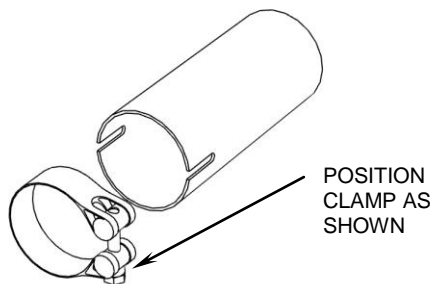

FIGURE 3
(FRONT VIEW)

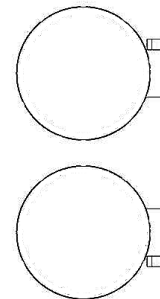

FIGURE 4
(FRONT VIEW)

- * Before starting your engine remove all fingerprints from chrome with a quality wax or chrome polish. Failure to do so can cause discoloration. Due to fluctuations in carburetor settings, timing, etc., Cobra Engineering does not warrant against chrome discoloration.

DISCLAIMER: NOT LEGAL FOR SALE OR USE IN CALIFORNIA ON ANY POLLUTION CONTROLLED MOTOR VEHICLE. THE SALE, USE, OR INSTALLATION OF THIS PRODUCT MAY ALSO BE ILLEGAL NATIONWIDE UNDER THE FEDERAL CLEAN AIR ACT (42 U.S.C. § 7522(A)(3)).