

## Items Supplied >

2 – FRONT & REAR EXHAUST HEADPIPE / HEATSHIELD ASSEMBLY  
1 – MUFFLER ASSEMBLY  
1 – EXHAUST MOUNT BRACKET  
4 – CLAMPS HS-24  
2 – CLAMPS HS-28  
2 – CLAMPS 27-61 MSC  
2 – BOLT, HEX 5/16-18 x 5/8"  
2 – BOLT, HEX 3/8 x 3/4"

## Application(s) >

HARLEY:  
FXST 07-10  
FXSTB 07-10  
FXSTC 07-10  
FXSTD 07-10  
FLSTF 07-10  
FLSTN 07-10  
FLSTSC 07-10  
FLSTC 07-10

## Instruction Manual >

6221

Page 1 of 2

**PRIOR TO INSTALLATION, MAKE SURE YOUR STOCK HEADPIPE GASKETS ARE IN GOOD SHAPE. IF YOU HAVE ANY DOUBTS AS TO THEIR CONDITION, REPLACE THEM.**

### Read all instructions carefully and completely before installing your new exhaust system

1. Unplug O<sub>2</sub> sensors on front and rear headpipes from motorcycle wire harnesses. Remove stock exhaust system. On some models you may need to remove the stock upper mounting bar. Using a #50 Torx driver, remove the three mounting bolts, and set the mounting bar aside. (Two of the bolts are visible; removing the right passenger foot peg will allow access to the third bolt.) Retain the stock 5/16" flange nuts for use later during reassembly.
2. Remove the two right floorboard/rear break lever mount bolts leaving the third in place, but loosen and rotate mount down out of the way. See Figure 1. This will make installation of exhaust and heatshields possible.
3. Remove the passenger footpegs. (Cobra offers a passenger footpeg relocation kit: Part #606-6220. Contact supplier or go to [www.cobrausa-hd.com](http://www.cobrausa-hd.com) for more information.)
4. Place the exhaust mount bracket on the motorcycle and bolt into place using the supplied 3/8" bolts. See Figure 2. **DO NOT FULLY TIGHTEN.**
5. Remove the flanges, retaining rings and O<sub>2</sub> sensors from the stock headpipes and install on new Cobra headpipes.
6. Install the front and rear headpipes on the motorcycle using the stock 5/16" flange nuts but do not tighten. Make sure the pipes are parallel with each other.
7. Remove the muffler assembly from the box and slide one supplied T-clamp #27-61MSC onto each muffler tube. Refer to Figure 3 for proper alignment.

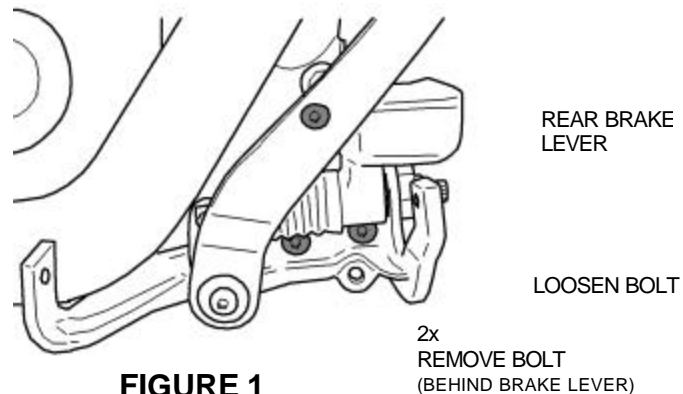

**FIGURE 1**

**\* Cobra recommends you always wear a helmet while riding. Please never operate your motorcycle while under the influence of alcohol and/or drugs. Enjoy the new look of your motorcycle and please ride safely.**

8. Slide the muffler assembly onto the head pipes by tapping on the head pipes with your hand as you push the muffler forward making sure the assembly slides as far forward as possible. Secure the muffler assembly to the mounting bracket using the supplied 5/16 bolts but **do not tighten**.
9. Make sure the muffler assembly is parallel with the head pipes (this is critical) then tighten the following in order, muffler bracket to the frame, muffler assembly to the muffler bracket, head pipe flanges to the motor (slowly tighten opposing nut) and muffler clamps. (NOTE: If the muffler clamps are slid to far up the muffler or past the two slots, the clamps will not tighten.) Plug O<sub>2</sub> sensors back into motorcycle harnesses.
10. Unscrew the remaining hose clamps and feed the tail end of the clamp through the clips on the inside of the heat shields. The screw end of the hose clamp should be accessible for tightening but not visible when the heat shields are mounted to the pipes. The larger HS-28 clamps go to the rear of the heatshields over the muffler bodies.
11. To install the front heatshield, first slide the rear portion of the heatshield over the muffler, continue to slowly slide it forward pushing the front of the shield gently into place between the frame and motor (Hint: Spread the hose clamps apart slightly to make it easier to slide them over the muffler assembly and head pipes). Make sure the muffler clamps don't interfere with the heatshields and are aligned as shown in Figure 3. Snug the heatshield clamps but **do not tighten**.
12. Install the rear heatshield the same way as the front heatshield. Tighten all clamps on both heatshields.
13. Rotate the floorboard mount back into place and retighten bolts to factory specifications. Reinstall the right floorboard with its original hardware.
14. Make sure all the hardware (brackets, headpipes, heatshields, mufflers and baffles) has been tightened appropriately and cleaned before starting your motorcycle.

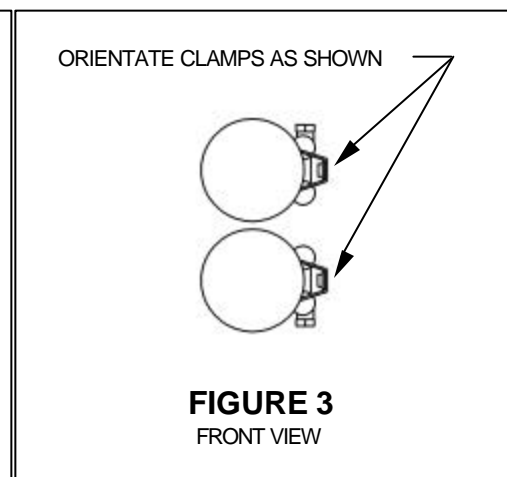
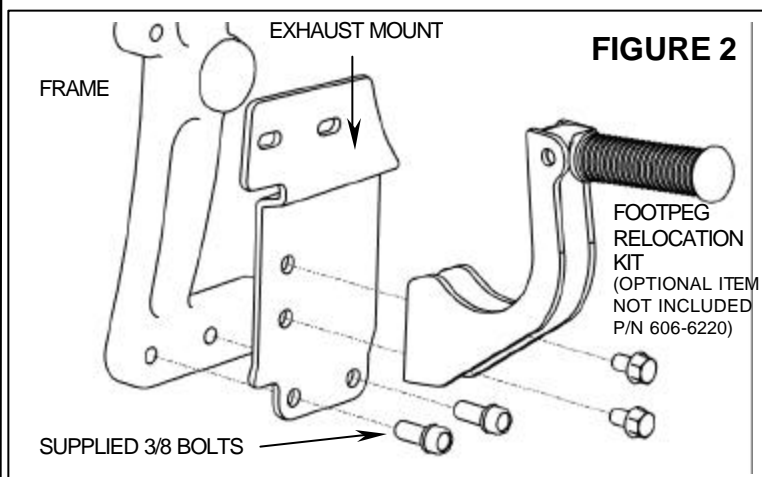

**IMPORTANT:** Your motorcycle is equipped with fuel injection; it is recommended that you install a Cobra Fi2000® Digital Fuel Processor with your Cobra exhaust system **Cobra Part #692-1607 for 2007 Models and Part #692-1614 for 2008-10 Models**. Cobra is not responsible for the performance of any other fuel management system used with Cobra exhaust systems.